

PENBERTHY SERIES 300 AND 400 OFFSET PATTERN FLAT GLASS GAUGE COCKS

Offset pattern gaugecocks that provide a 90° connection to the process vessel and isolate the gauge chamber from the liquid content of the vessel



Model 330



Model 430

FEATURES

- Offset pattern allows easy cleaning
- Integral bonnet (300 series)
- Union bonnet (400 series)
- Union vessel connection
- Ball check shut-off prevents loss of process fluid in the event of an accidental breakage of the gauge glass
- Integral seat (300 series)
- Threaded renewable seat (400 series)
- Can be supplied to meet ASME requirements
- Wide variety of gauge and vessel connections available

GENERAL APPLICATION

These gaugecocks have internal screw threads that are wetted by the process liquid. They are used in conjunction with direct reading flat glass gauges in the petroleum, chemical and general process industries.

TECHNICAL DATA

Materials:	Forged CS, LTCS, 316SS
Sizes:	½" to 1" (DN 15 to 25)
Gauge connection	
Model 320/420:	Union
Model 330/430:	Rigid
Pressure (max):	4000 psi at 100°F (275.8 bar at 38°C)
Temperature range:	-300°F to 750°F (-184°C to 399°C)

PENBERTHY®

16633 Foltz Parkway, Strongsville, OH 44149 USA • Telephone: +440-572-1500
www.PenberthyProcess.com • sales@PenberthyProcess.com

PRODUCT OVERVIEW

The 300 and 400 series includes models 320/420 and 330/430. These gaugecocks have inside screw threads that are wetted by the liquid. They are offered with a wide range of features in an offset pattern design.

Offset gaugecocks have the advantage of permitting the inside of the gauge glass to be cleaned easily with a minimum of disassembly. By removing the vent and drain plugs (or other connection), a straight passage is opened through the gauge chamber. A brush can be inserted through the gaugecock vent and drain for glass cleaning.

Gaugecock seat leakage is Class I per ISA RP39.6, FCI 70-2 (formerly ASME B16. 105) and/or IEC 60534-4.

A variety of optional features are available when specified. Optional materials can be specified for the gaugecock body and trim (trim consists of the stem, stem packing retainer, ball check, and seat (400 series only)). Standard and optional materials conform to ASTM specifications.

CENTER-TO-CENTER DIMENSIONS, in (cm)

Model	Dimension X	Dimension Y
320/420	5½ (14.9)	3¾ (9.2)
330/430	2¾ (7.3)	¾ (1.6)

To obtain the maximum length permissible for given vessel center-to-center dimension using ½” nipples:

Maximum gauge length = (gaugecock center-to center dimension) - (dimension X)

To determine the overall length of nipples needed to make up a gauge set for fixed vessel centerto-center dimension using ½” nipples:

Combined nipple length = (gaugecock center-to-center dimension) - (gauge length + dimension Y)

Overall nipple length can be divided between nipples to suit the application. Minimum length required for each nipple is: 1⅝” for ½” NPT nipple; 1⅞” for ¾” NPT nipple.

A floating shank union vessel connection permits the gaugecock center-to-center dimension to vary ⅜” (9.5 mm) total from the actual vessel center-to-center dimension.

PRESSURE/TEMPERATURE

Maximum working pressure psi (kPa) at temperatures to:										
-300°F (-184°C)	-150°F (-101°C)	-20°F (-29°C)	100°F (38°C)	200°F (93°C)	300°F (149°C)	400°F (204°C)	500°F (260°C)	550°F (288°C)	750°F (399°C)	
**	-	-	4000 (27580)	4000 (27580)	3900 (26890)	3815 (26300)	3730 (25720)	3525 (24300)	3355 (23130)	2620 (18040)
***	4000 (27580)	4000 (27580)	4000 (27580)	4000 (27580)	3900 (26890)	3815 (26300)	3730 (25720)	3525 (24300)	3355 (23130)	2755 (18990)

- ** Carbon Steel
- *** Stainless Steel

AUTOMATIC BALL CHECK SHUT-OFF

To prevent rapid loss of fluid in the event of accidental glass breakage, Penberthy gaugecocks are supplied with automatic ball check shut-off. Should the glass break, the pressure drop causes the ball checks to seat to prevent loss of tank contents. To unseat these ball checks during the liquid level readings, the tip of the gaugecock stem has an extension that pushes the ball away from its seat while allowing the gauge column to fill as liquid contents pass around the ball. Stainless steel retainers prevent reverse seating of balls or loss of balls during installation.

Both upper and lower gaugecocks in each set are equipped with horizontal ball checks. Ball CHECKS are located on the vessel side of the gaugecock seats.

ASME BOILER CODE

Gaugecocks with ball checks omitted meet ASME boiler requirements. As an alternative method to ASME boiler requirements, the lower gaugecock on models 320/420 is available with an optional vertical rising ball check located in the offset portion of the gaugecock body and the upper gaugecock has a leaky seat.

VERTICALLY RISING BALL CHECK

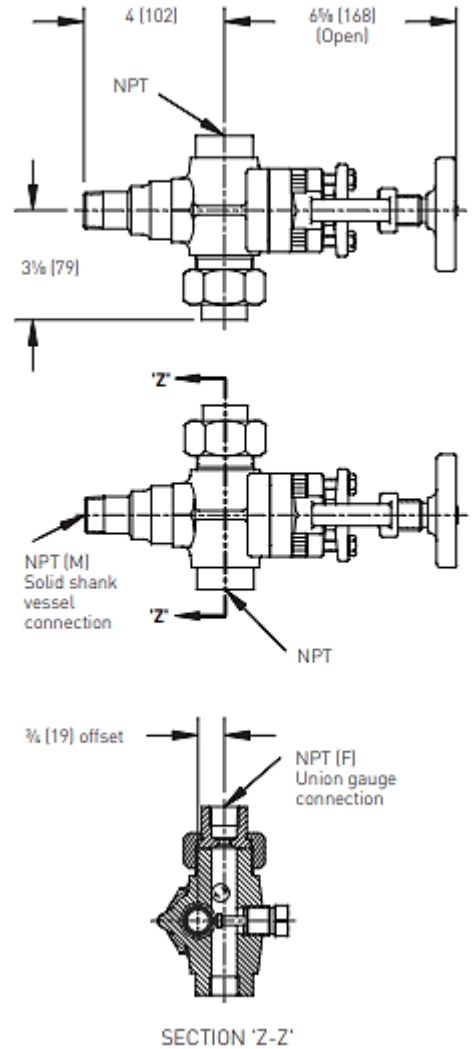

PENBERTHY SERIES 300 AND 400 OFFSET PATTERN FLAT GLASS GAUGECOCKS
SERIES 300 - DIMENSIONS

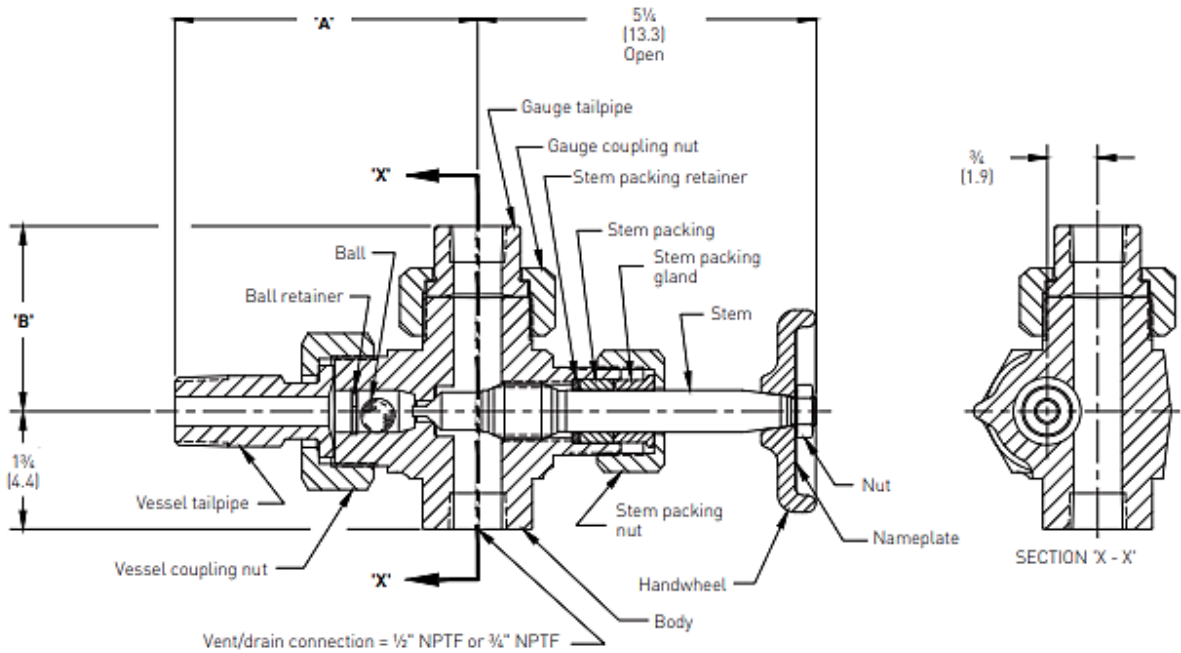

In. (cm)

SERIES 300 - DIMENSIONS

Connection	Dimension 'A' inches (cm)	Dimension 'B' inches (cm)	
		Standard	320 option / Side connect
Union			
1/2" NPTF	3 3/8 (8.1)	2 3/8 (7.0)	-
1/2" NPTM	4 1/8 (11.1)	3 3/8 (8.6)	4 1/8 (10.3)
3/4" NPTF	3 3/8 (8.1)	2 3/8 (7.0)	-
3/4" NPTM	4 1/2 (11.4)	3 3/8 (8.6)	4 1/8 (10.3)
1" NPTM	4 3/8 (11.7)	-	-
Rigid			
1/2" NPTF	-	1 1/4 (3.2)	-
3/4" NPTF	-	1 1/4 (3.2)	-
Solid shank			
1/2" NPTM	4 (10.2)	-	-
3/4" NPTM	4 (10.2)	-	-
1" NPTM	4 (10.2)	-	-
Socketweld			
1/2" Female union	-	2 3/8 (7.0)	-
1/2" Female rigid	-	1 1/4 (3.2)	-
1/2" Male union	4 3/8 (11.1)	3 3/8 (8.6)	4 1/8 (10.3)
3/4" Female rigid	-	1 1/4 (3.2)	-
3/4" Male union	4 1/2 (11.4)	3 3/8 (8.6)	4 1/8 (10.3)
1" Male union	4 3/8 (11.7)	-	-
Spherical union			
1/2" NPTF	4 1/8 (11.6)	4 1/8 (10.5)	-
1/2" NPTM	4 1/8 (11.6)	4 1/8 (10.5)	-
3/4" NPTM	4 1/8 (11.6)	4 1/8 (10.5)	-

PENBERTHY SERIES 300 AND 400 OFFSET PATTERN FLAT GLASS GAUGECOCKS
SERIES 300 - DIMENSIONS

SERIES 300 - DIMENSIONS - FLANGED CONNECTION

Flanged connection	Dimension 'A' inches (cm)		Dimension 'B' inches (cm)	
	RF Threaded	RF Slip on	RF Threaded	RF Slip on
Union				
½" - 150 P-Cl (F)	-	-	3 11/16 [9.4]	3 9/16 [9.7]
½" - 300 P-Cl (F)	-	-	3 5/8 [10.0]	3 13/16 [10.0]
½" - 600 P-Cl (F)	-	-	4 1/8 [10.6]	4 1/4 [10.6]
½" - 1500 P-Cl (F)	-	-	4 9/16 [12.2]	4 3/4 [12.1]
½" - 150 P-Cl (M)	4 1/8 [11.4]	4 3/8 [11.7]	3 11/16 [9.4]	3 3/4 [9.2]
½" - 300 P-Cl (M)	4 1/8 [11.4]	4 3/8 [11.7]	3 3/4 [9.5]	3 3/4 [9.5]
½" - 600 P-Cl (M)	4 3/8 [12.1]	4 3/8 [11.7]	4 1/8 [10.3]	4 1/8 [10.3]
½" - 1500 P-Cl (M)	5 [12.7]	4 3/8 [11.7]	4 3/8 [12.1]	4 3/8 [12.1]
¾" - 150 P-Cl (F)	-	-	3 5/8 [10.0]	-
¾" - 300 P-Cl (F)	-	-	4 1/8 [10.6]	-
¾" - 600 P-Cl (F)	-	-	4 3/8 [11.3]	-
¾" - 1500 P-Cl (F)	-	-	4 9/16 [12.5]	-
¾" - 150 P-Cl (M)	4 3/8 [11.7]	4 3/8 [12.1]	3 3/4 [9.5]	3 3/4 [9.5]
¾" - 300 P-Cl (M)	4 3/8 [11.7]	4 3/8 [12.1]	4 3/8 [10.5]	4 1/8 [10.3]
¾" - 600 P-Cl (M)	5 [12.7]	4 3/8 [12.1]	4 3/8 [11.1]	4 3/8 [11.0]
¾" - 1500 P-Cl (M)	5 1/4 [13.3]	4 3/8 [12.1]	4 3/8 [12.4]	4 3/8 [12.4]
Rigid				
¾" - 150 P-Cl (F)	-	-	2 5/8 [7.5]	2 3/4 [7.3]
¾" - 300 P-Cl (F)	-	-	3 3/8 [8.1]	3 1/2 [8.1]
¾" - 600 P-Cl (F)	-	-	3 7/8 [8.7]	3 1/2 [8.7]
¾" - 1500 P-Cl (F)	-	-	4 1/8 [10.3]	4 [10.2]
Union				
1" - 150 P-Cl (M)	4 11/16 [11.9]	4 3/8 [12.4]	3 3/4 [9.5]	3 3/4 [9.5]
1" - 300 P-Cl (M)	4 11/16 [11.9]	4 3/8 [12.4]	4 3/8 [10.5]	4 1/8 [10.3]
1" - 600 P-Cl (M)	5 1/8 [12.9]	4 3/8 [12.4]	4 3/8 [11.1]	4 3/8 [11.0]
1" - 1500 P-Cl (M)	5 3/4 [13.7]	4 3/8 [12.4]	-	-

GAUGE CONNECTIONS

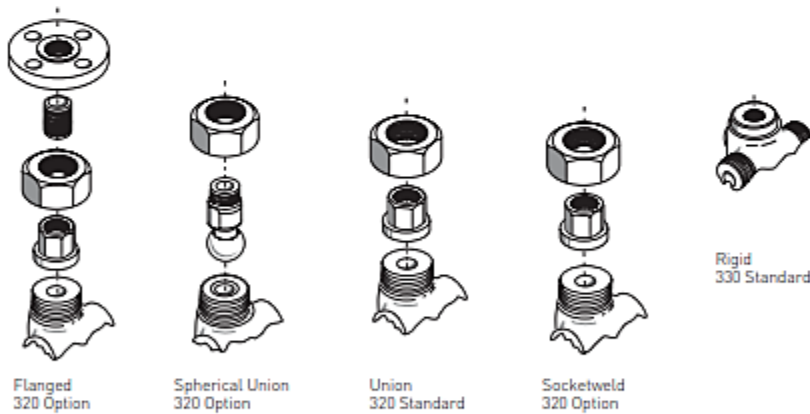

VESSEL CONNECTIONS

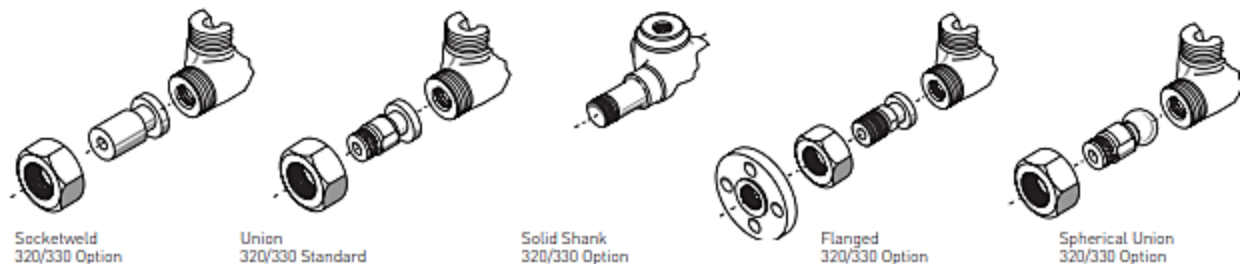

PENBERTHY SERIES 300 AND 400 OFFSET PATTERN FLAT GLASS GAUGE COCKS
SERIES 300 - MATERIALS

SERIES 300 MATERIALS

Ref. no.	Description	Standard materials				Optional materials
		Carbon steel to -20°F	STS construction to -325°F	Sour gas service to -20°F	Low-temp. to -50°F	
11	Body	ASTM A105 (forged) carbon steel	ASTM A182 (forged) Gr. F316/F316L STS	ASTM A105 (forged) carbon steel per NACE MR0175 and/or MR0103	ASTM A350 (forged) carbon steel Gr. LF2 CL. 1	ASTM A351 304/304L STS Gr. CF3 ASTM A351 316/316L STS Gr. CF3M ASTM A182 Gr. F304/F304L STS ASTM A182 Gr. F51 Duplex 2205 STS ASTM A494 Hastelloy B [®] Gr. N-12MV ASTM A352 carbon steel Gr. LCC ASTM A743 Alloy 20 Gr. CN7M ASTM B564 Monel [®] 400 N04400 ASTM A494 Hastelloy C [®] Gr. CW12MW ASTM A123 galvanized steel
12	Vessel tailpipe	ASTM A108 carbon steel AISI C1018	ASTM A276 316/316L STS	ASTM A108 carbon steel AISI C1018 per NACE MR0175 and/or MR0103	ASTM A350 carbon steel Gr. LF2 CL. 1	ASTM A276 304/304L, Duplex 2205 STS ASTM B164 Monel [®] 400 ASTM B473 Alloy 20 [CARP 20Cb-3] [®] ASTM B335 Hastelloy B [®]
13	Vessel coupling nut	ASTM A108 carbon steel AISI C1018	Investment cast 316 STS	ASTM A108 carbon steel AISI C1018 per NACE MR0175 and/or MR0103	Investment cast 316 STS	ASTM B574 Hastelloy C [®] 276 ASTM A123 galvanized steel
14	Ball retainer	ASTM A313 316 STS (spring wire)				None
15	T R I M Ball	ASTM A493, A262 or A276 316 STS				ASTM B574 Hastelloy C [®] 276 Borosilicate glass ASTM B473 Alloy 20 [CARP 20Cb-3] [®] ASTM B164 Monel [®] 400 ASTM B335 Hastelloy B [®] CRS 304 STS ASTM A276 Duplex 2205 STS
17						Stem
18	Stem packing retainer	MPIF SS-316N2-33 316 STS (sintered)				ASTM B473 Alloy 20 [CARP 20Cb-3] [®] ASTM B335 Hastelloy B [®] ASTM B574 Hastelloy C [®] 276
19	Stem packing gland					
25	Stem packing	Graphite composite				Teflon [®] Viton [®]
26	Stem packing nut	ASTM A108 carbon steel AISI C1018	Investment cast 316/316L STS	ASTM A108 carbon steel AISI C1018	Investment cast 316/316L STS	ASTM A276 304/304L, Duplex 2205 STS ASTM B164 Monel [®] 400 ASTM B473 Alloy 20 [CARP 20Cb-3] [®] ASTM B335 Hastelloy B [®] ASTM B574 Hastelloy C [®] 276 ASTM A123 galvanized steel
28	Handwheel	ASTM A216 Carbon steel Gr. WCB				None
30	Handwheel nut	ASTM A563 Steel Gr. A				None
320 Gaugecock						
31	Gauge tailpipe	ASTM A108 carbon steel AISI C1018	ASTM A276 316/316L STS	ASTM A108 carbon steel AISI C1018 per NACE MR0175 and/or MR0103	ASTM A350 carbon steel Gr. LF2 CL. 1	ASTM A276 304/304L, Duplex 2205 STS ASTM B164 Monel [®] 400 ASTM B473 Alloy 20 [CARP 20Cb-3] [®] ASTM B335 Hastelloy B [®]
32	Gauge coupling nut	ASTM A108 carbon steel AISI C1018	Investment cast 316 STS	ASTM A108 carbon steel AISI C1018 per NACE MR0175 and/or MR0103	Investment cast 316 STS	ASTM B574 Hastelloy C [®] 276 ASTM A123 galvanized steel

PENBERTHY SERIES 300 AND 400 OFFSET PATTERN FLAT GLASS GAUGECOCKS
SERIES 400 - DIMENSIONS

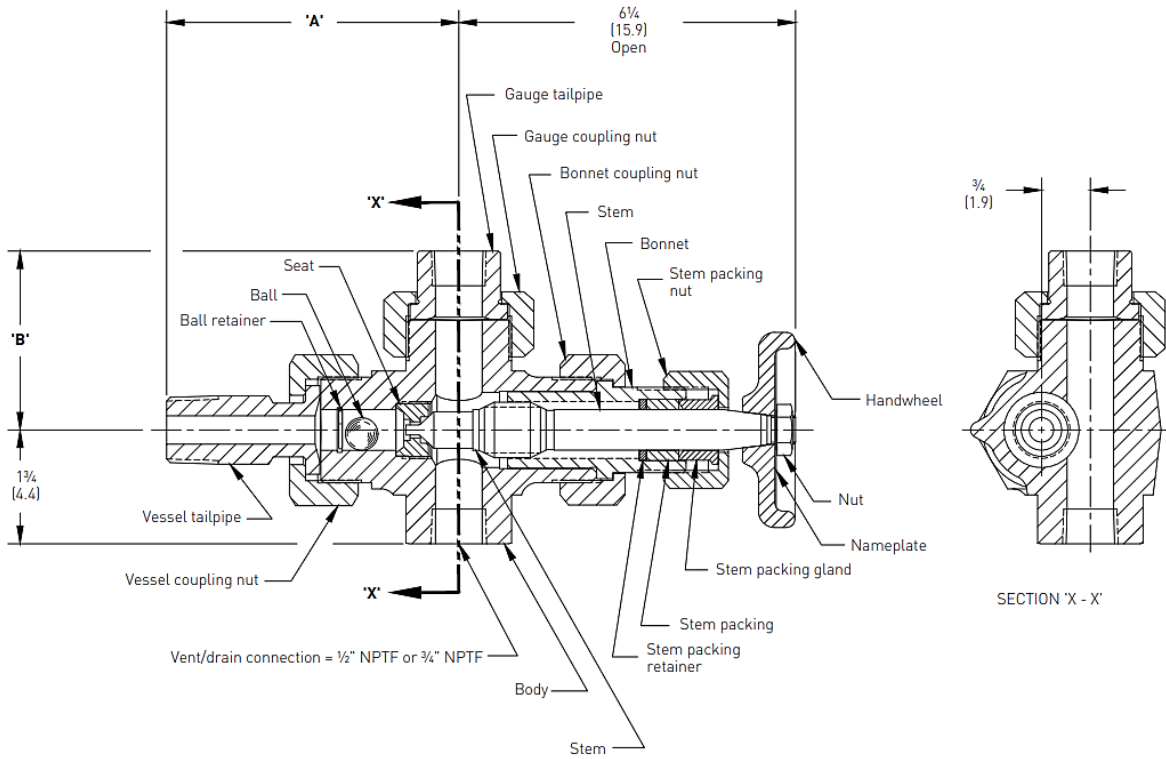

In. (cm)

SERIES 400 - DIMENSIONS

Connection	Dimension 'A' inches (cm)	Dimension 'B' inches (cm)	
		Standard	420 option / Side connect
Union			
1/2" NPTF	3 3/16 [8.1]	2 3/4 [7.0]	-
1/2" NPTM	4 3/8 [11.1]	3 3/8 [8.6]	4 1/16 [10.3]
3/4" NPTF	3 3/16 [8.1]	2 3/4 [7.0]	-
3/4" NPTM	4 1/2 [11.4]	3 3/8 [8.6]	4 1/16 [10.3]
1" NPTM	4 5/8 [11.7]	-	-
Rigid			
1/2" NPTF	-	1 1/4 [3.2]	-
3/4" NPTF	-	1 1/4 [3.2]	-
Solid shank			
1/2" NPTM	4 [10.2]	-	-
3/4" NPTM	4 [10.2]	-	-
1" NPTM	4 [10.2]	-	-
Socketweld			
1/2" Female union	-	2 3/4 [7.0]	-
1/2" Female rigid	-	1 1/4 [3.2]	-
1/2" Male union	4 3/8 [11.1]	3 3/8 [8.6]	4 1/16 [10.3]
3/4" Female rigid	-	1 1/4 [3.2]	-
3/4" Male union	4 1/2 [11.4]	3 3/8 [8.6]	4 1/16 [10.3]
1" Male union	4 5/8 [11.7]	-	-
Spherical union			
1/2" NPTF	4 7/16 [11.6]	4 1/8 [10.5]	-
1/2" NPTM	4 7/16 [11.6]	4 1/8 [10.5]	-
3/4" NPTM	4 7/16 [11.6]	4 1/8 [10.5]	-

PENBERTHY SERIES 300 AND 400 OFFSET PATTERN FLAT GLASS GAUGECOCKS
SERIES 400 - DIMENSIONS

SERIES 400 - DIMENSIONS - FLANGED CONNECTION

Flanged connection	Dimension 'A' inches (cm)		Dimension 'B' inches (cm)	
	RF Threaded	RF Slip on	RF Threaded	RF Slip on
Union				
½" - 150 P-Cl (F)	-	-	3 ¹¹ / ₁₆ (9.4)	3 ¹³ / ₁₆ (9.7)
½" - 300 P-Cl (F)	-	-	3 ¹⁵ / ₁₆ (10.0)	3 ¹⁵ / ₁₆ (10.0)
½" - 600 P-Cl (F)	-	-	4 ³ / ₁₆ (10.6)	4 ³ / ₁₆ (10.6)
½" - 1500 P-Cl (F)	-	-	4 ¹³ / ₁₆ (12.2)	4 ³ / ₄ (12.1)
½" - 150 P-Cl (M)	4½ (11.4)	4 ⁵ / ₈ (11.7)	3 ¹¹ / ₁₆ (9.4)	3 ⁵ / ₈ (9.2)
½" - 300 P-Cl (M)	4½ (11.4)	4 ⁵ / ₈ (11.7)	3 ³ / ₄ (9.5)	3 ³ / ₄ (9.5)
½" - 600 P-Cl (M)	4 ³ / ₄ (12.1)	4 ⁵ / ₈ (11.7)	4 ¹ / ₁₆ (10.3)	4 ¹ / ₁₆ (10.3)
½" - 1500 P-Cl (M)	5 (12.7)	4 ⁵ / ₈ (11.7)	4 ³ / ₄ (12.1)	4 ³ / ₄ (12.1)
¾" - 150 P-Cl (F)	-	-	3 ¹⁵ / ₁₆ (10.0)	-
¾" - 300 P-Cl (F)	-	-	4 ³ / ₁₆ (10.6)	-
¾" - 600 P-Cl (F)	-	-	4 ⁷ / ₁₆ (11.3)	-
¾" - 1500 P-Cl (F)	-	-	4 ¹⁵ / ₁₆ (12.5)	-
¾" - 150 P-Cl (M)	4 ⁵ / ₈ (11.7)	4 ³ / ₄ (12.1)	3 ³ / ₄ (9.5)	3 ³ / ₄ (9.5)
¾" - 300 P-Cl (M)	4 ⁵ / ₈ (11.7)	4 ³ / ₄ (12.1)	4 ¹ / ₁₆ (10.5)	4 ¹ / ₁₆ (10.3)
¾" - 600 P-Cl (M)	5 (12.7)	4 ³ / ₄ (12.1)	4 ⁹ / ₁₆ (11.1)	4 ⁹ / ₁₆ (11.0)
¾" - 1500 P-Cl (M)	5¼ (13.3)	4 ³ / ₄ (12.1)	4 ⁷ / ₈ (12.4)	4 ⁷ / ₈ (12.4)
Rigid				
¾" - 150 P-Cl (F)	-	-	2 ¹⁵ / ₁₆ (7.5)	2 ⁷ / ₈ (7.3)
¾" - 300 P-Cl (F)	-	-	3 ³ / ₁₆ (8.1)	3 ³ / ₁₆ (8.1)
¾" - 600 P-Cl (F)	-	-	3 ⁷ / ₁₆ (8.7)	3 ⁷ / ₁₆ (8.7)
¾" - 1500 P-Cl (F)	-	-	4 ¹ / ₁₆ (10.3)	4 (10.2)
Union				
1" - 150 P-Cl (M)	4 ¹ / ₁₆ (11.9)	4 ⁷ / ₈ (12.4)	3 ³ / ₄ (9.5)	3 ³ / ₄ (9.5)
1" - 300 P-Cl (M)	4 ¹ / ₁₆ (11.9)	4 ⁷ / ₈ (12.4)	4 ¹ / ₁₆ (10.5)	4 ¹ / ₁₆ (10.3)
1" - 600 P-Cl (M)	5 ¹ / ₁₆ (12.9)	4 ⁷ / ₈ (12.4)	4 ⁹ / ₁₆ (11.1)	4 ⁹ / ₁₆ (11.0)
1" - 1500 P-Cl (M)	5 ⁵ / ₈ (13.7)	4 ⁷ / ₈ (12.4)	-	-

GAUGE CONNECTIONS

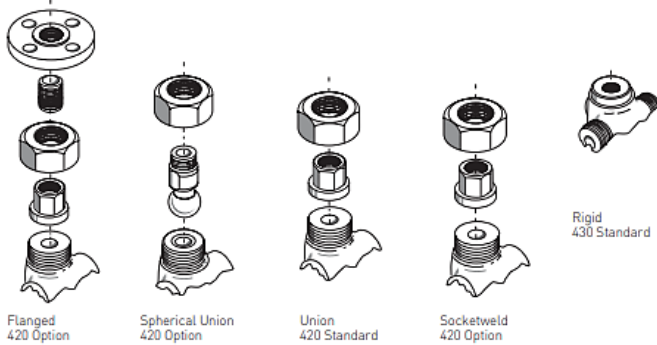

VESSEL CONNECTIONS

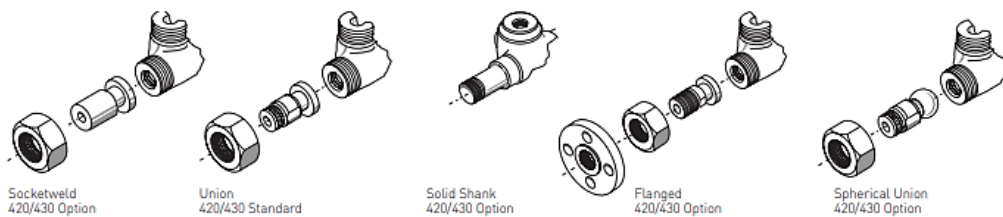

PENBERTHY SERIES 300 AND 400 OFFSET PATTERN FLAT GLASS GAUGE COCKS
SERIES 400 - MATERIALS

SERIES 400 MATERIALS

Ref. no.	Description	Standard materials				Optional materials
		Carbon steel to -20°F	STS construction to -325°F	Sour gas service to -20°F	Low-temp. to -50°F	
11	Body	ASTM A105 (forged) carbon steel	ASTM A182 (forged) Gr. F316/F316L STS	ASTM A105 (forged) carbon steel per NACE MR0175 and/or MR0103	ASTM A350 (forged) carbon steel Gr. LF2 CL 1	ASTM A351 304/304L STS Gr. CF3 ASTM A351 316/316L STS Gr. CF3M ASTM A182 Gr. F304/F304L STS ASTM A182 Gr. F51 Duplex 2205 STS ASTM A494 Hastelloy B [®] Gr. N-12MV ASTM A352 carbon steel Gr. LCC ASTM A743 Alloy 20 Gr. CN7M ASTM B564 Monel [®] 400 N04400 ASTM A494 Hastelloy C [®] Gr. CW12MW ASTM A123 galvanized steel
12	Vessel tailpipe	ASTM A108 carbon steel AISI C1018	ASTM A276 316/316L STS	ASTM A108 carbon steel AISI C1018 per NACE MR0175 and/or MR0103	ASTM A350 carbon steel Gr. LF2 CL 1	ASTM A276 304/304L STS ASTM A276 Duplex 2205 STS ASTM B164 Monel [®] 400 ASTM B473 Alloy 20 [CARP 20Cb-3] [®]
13	Vessel coupling nut	ASTM A108 carbon steel AISI C1018	Investment cast 316 STS		Investment cast 316 STS	ASTM B335 Hastelloy B [®] ASTM B574 Hastelloy C [®] 276 ASTM A123 Galvanized steel
14	Ball retainer	ASTM A313 316 STS (spring wire)				None
15	T R I M	Ball	ASTM A493, A262 or A276 316 STS			ASTM B574 Hastelloy C [®] 276 Borosilicate glass ASTM B473 Alloy 20 [CARP 20Cb-3] [®] ASTM B164 Monel [®] 400 ASTM B335 Hastelloy B [®] CRS 304 STS ASTM A276 Duplex 2205 STS
16		Seat	ASTM A276 316/316L STS			
17		Stem	ASTM A276 316/316L STS	ASTM A276 316/316L STS per NACE MR0175 and/or MR0103	ASTM A582 416 STS or ASTM A276 410 STS	ASTM A276 316/316L STS ASTM A276 304/304L STS ASTM A276 Duplex 2205 STS ASTM B164 Monel [®] 400
18		Stem packing retainer	MPIF SS-316N2-33 316 STS (sintered)			ASTM B473 Alloy 20 [CARP 20Cb-3] [®] ASTM B335 Hastelloy B [®] ASTM B574 Hastelloy C [®] 276
19	Stem packing gland					
20	Bonnet	ASTM A108 carbon steel AISI C1018	ASTM A276 316/316L STS	ASTM A108 carbon steel AISI C1018 per NACE MR0175 and/or MR0103	ASTM A350 Carbon steel Gr. LF2 CL 1	ASTM A276 304/304L STS ASTM A276 Duplex 2205 STS ASTM B164 Monel [®] 400 ASTM B473 Alloy 20 [CARP 20Cb-3] [®]
21	Bonnet nut	ASTM A108 carbon steel AISI C1018	Investment cast 316 STS	ASTM A108 carbon steel AISI C1018	Investment cast 316 STS	ASTM B335 Hastelloy B [®] ASTM B574 Hastelloy C [®] 276 ASTM A123 galvanized steel
25	Stem packing	Graphite composite				Teflon [®] Viton [®]
26	Stem packing nut	ASTM A108 carbon steel AISI C1018	Investment cast 316/316L STS	ASTM A108 carbon steel AISI C1018	Investment cast 316/316L STS	ASTM A276 304/304L, Duplex 2205 STS ASTM B164 Monel [®] 400 ASTM B473 Alloy 20 [CARP 20Cb-3] [®] ASTM B335 Hastelloy B [®] ASTM B574 Hastelloy C [®] 276 ASTM A123 galvanized steel
28	Handwheel	ASTM A216 Carbon steel Gr. WCB				None
30	Handwheel nut	ASTM A563 Steel Gr. A				None
420 Gaugecock						
31	Gauge tailpipe	ASTM A108 carbon steel AISI C1018	ASTM A276 316/316L STS	ASTM A108 carbon steel AISI C1018 per NACE MR0175 and/or MR0103	ASTM A350 carbon steel Gr. LF2 CL 1	ASTM A276 304/304L, Duplex 2205 STS ASTM B164 Monel [®] 400 ASTM B473 Alloy 20 [CARP 20Cb-3] [®]
32	Gauge coupling nut	ASTM A108 carbon steel AISI C1018	Investment cast 316 STS		Investment cast 316 STS	ASTM B335 Hastelloy B [®] ASTM B574 Hastelloy C [®] 276 ASTM A123 galvanized steel

PENBERTHY SERIES 300 AND 400 OFFSET PATTERN FLAT GLASS GAUGE COCKS FEATURES

STANDARD/OPTIONAL FEATURES

Feature	320		420		330		430	
	Std.	Opt.	Std.	Opt.	Std.	Opt.	Std.	Opt.
Pattern								
Offset	X	-	X	-	X	-	X	-
Bonnet								
Integral	X	-	-	-	X	-	-	-
Union	-	-	X	-	-	-	X	-
Gauge connection								
Union	½" NPTF	X	-	X	-	-	-	-
	½" NPTM	-	X	-	X	-	-	-
	¾" NPTF	-	X	-	X	-	-	-
	¾" NPTM	-	X	-	X	-	-	-
Rigid	½" NPTF	-	-	-	-	X	-	X
	¾" NPTF	-	-	-	-	-	X	-
Socketweld	½" Female	-	X	-	X	-	X	-
	½" Male	-	X	-	X	-	-	-
	¾" Male	-	X	-	X	-	-	-
	¾" Female	-	-	-	-	-	X	-
Flanged	-	X	-	X	-	X	-	X
Spherical union	½" NPTF	-	X	-	X	-	-	-
	½" NPTM	-	X	-	X	-	-	-
	¾" NPTM	-	X	-	X	-	-	-
Vessel connection								
Union	½" NPTF	-	X	-	X	-	X	-
	½" NPTM	-	X	-	X	-	X	-
	¾" NPTM	X	-	X	-	X	-	X
	1" NPTM (non floating)	-	X	-	X	-	X	-
Solid shank	½" NPTM	-	X	-	X	-	X	-
	¾" NPTM	-	X	-	X	-	X	-
	1" NPTM	-	X	-	X	-	X	-
Socketweld	½" Male	-	X	-	X	-	X	-
	¾" Male	-	X	-	X	-	X	-
	1" Male	-	X	-	X	-	X	-
Flanged	-	X	-	X	-	X	-	X
Spherical union	½" NPTF	-	X	-	X	-	X	-
	½" NPTM	-	X	-	X	-	X	-
	¾" NPTM	-	X	-	X	-	X	-
Vent/drain connection								
½" NPTF	X	-	X	-	X	-	X	-
¾" NPTF	-	X	-	X	-	X	-	X
Ball check shut-off								
Horizontal lower and upper gaugecocks	X	-	X	-	X	-	X	-
Vertical lower/horizontal upper gaugecock*	-	X	-	X	-	-	-	-
Omitted*	-	X	-	X	-	X	-	X
Vacuum - horizontal upper and lower	-	X	-	X	-	X	-	X
Seat								
Integral	X	-	-	-	X	-	-	-
Threaded (renewable)	-	-	X	-	-	-	X	-
Backseating stem	-	-	-	X	-	-	-	X
Handwheel								
w/standard pitch threads	X	-	X	-	X	-	X	-
w/quick closing thread	-	X	-	X	-	X	-	X
Lever								
w/quick closing thread (¼ turn)	-	X	-	X	-	X	-	X

* Acceptable for ASME service

PENBERTHY SERIES 300 AND 400 OFFSET PATTERN FLAT GLASS GAUGE COCKS
SELECTION GUIDE - PART 1

SELECTION GUIDE

Example:	320	C	C	X	E
Model					
320	Model 320				
321	Model 320 with gasketed vessel tailpipe				
322	Model 320 with gasketed gauge tailpipe				
323	Model 320 with gasketed vessel and gauge tailpipe				
330	Model 330				
331	Model 330 with gasketed vessel tailpipe				
420	Model 420				
421	Model 420 with gasketed vessel tailpipe				
422	Model 420 with gasketed gauge tailpipe				
423	Model 420 with gasketed vessel and gauge tailpipe				
430	Model 430				
431	Model 430 with gasketed vessel tailpipe				
Body Material					
C	Carbon Steel (Standard)				
S	316/316L Stainless Steel				
L	Low-temp carbon steel				
M	Monel®				
A	Alloy 20				
H	Hastelloy C®				
D	Duplex 2205				
F	304/304L Stainless Steel				
I	Incoloy 625				
N	A105N				
B	A182 F9 body/tlp/flg				
Trim Material					
C	416 Stainless Steel (Standard)				
S	316/316L Stainless Steel				
B	410 Stainless Steel				
M	Monel®				
A	Alloy 20				
H	Hastelloy C®				
D	Duplex 2205 Stainless Steel				
F	304/304L Stainless Steel				
I	Incoloy 625				
NACE MR-01-75 a/or MR-0103					
X	None				
E	Environmental				

Vessel Connection Size

C	½"
E	¾" (standard)
F	1"
G	1¼" (flange only)
H	1½" (flange only)
J	2" (flange only)
K	2½" (flange only)
L	3" (flange only)

PART 2 - PAGE 12

A X C



PART 3 - PAGE 13

A X C A



PART 4 - PAGE 14

C A G S S

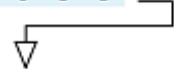

PART 5 - PAGE 15

X X X X X



PENBERTHY SERIES 300 AND 400 OFFSET PATTERN FLAT GLASS GAUGE COCKS
SELECTION GUIDE - PART 2

PART 1 - PAGE 11

SELECTION GUIDE - PART 2

PART 3 - PAGE 13

320 C C X E

Example:

A X C

A X C A

- Vessel Connection Type**
- A** NPTM union (standard)
 - B** NPTF union
 - C** Socket weld male union
 - D** Socket weld female union
 - E** Spherical union NPTM
 - F** Spherical union NPTF
 - G** Spherical union SWM
 - H** Spherical union SWF
 - L** Welded solid shank NPTM
 - M** Welded solid shank SWM
 - N** Raised face SO flange
 - P** Flat face SO flange
 - R** RTJ SO flange
 - S** Raised face SW flange
 - T** Flat face SW flange
 - U** RTJ SW flange
 - V** Raised face WN flange
 - W** Flat face WN flange
 - Y** RTJ WN flange
 - Z** Spherical union RTJ SO flange
 - 1** Spherical union RF SO flange
 - 2** Spherical union RF WN flange
 - 4** Spherical union RTJ WN flange
 - 5** Welded SSV flanged
 - 6** Raised face threaded flange
 - 7** Vessel Tip and Cplg nut omitted

Vessel Connection Pressure Class (If Flanged)

- X** None
- 1** P CL #150
- 3** P CL #300
- 6** P CL #600
- 9** P CL #900
- F** P CL #1500
- T** P CL #2500

Gauge Connection Size

- X** None
- C** 1/8" (standard)
- E** 3/16"
- F** 1" (flange only)
- G** 1 1/4" (flange only)
- H** 1 1/2" (flange only)
- J** 2" (flange only)
- K** 2 1/2" (flange only)
- L** 3" (flange only)

PART 4 - PAGE 14

C A G S S

PART 5 - PAGE 15

X X X X X

PENBERTHY SERIES 300 AND 400 OFFSET PATTERN FLAT GLASS GAUGE COCKS
SELECTION GUIDE - PART 3

PART 1 - PAGE 11

320 C C X E

PART 2 - PAGE 12

A X C

SELECTION GUIDE - PART 3

Example: A X C A

- Gauge connection type**
- A NPTF union (standard on 32X or 42X model)
 - D Socket weld female union
 - G Spherical union NPTF
 - H Spherical union NPTM
 - J Spherical union SWF
 - K Spherical union SWM
 - Y NPTF rigid (standard on 33X or 43X model)
 - Z SWF rigid
 - L Raised face SO flange
 - M Flat face SO flange
 - N RTJ SO flange
 - P Raised face SW flange
 - R Flat face SW flange
 - S RTJ SW flange
 - T Raised face WN flange
 - U Flat face WN flange
 - V RTJ WN flange
 - 1 NPTM union flange
 - B NPTM union 1¹/₄" L
 - C NPTM union 2³/₄" L
 - E SWM union 1¹/₄" L
 - F SWM union 2³/₄" L
 - 2 Socket weld female Coupling
 - 5 Raised face treaded

Gauge Connection Pressure Class (If Flanged)

- X None
- 1 P CL #150
- 3 P CL #300
- 6 P CL #600
- 9 P CL #900
- F P CL #1500
- T P CL #2500

Vent Connection Size

- X None
- C 1/2" (standard)
- E 3/4"
- F 1" (flange only)
- G 1 1/4" (flange only)
- H 1 1/2" (flange only)
- J 2" (flange only)
- K 2 1/2" (flange only)
- L 3" (flange only)

Vent Connection Type

- X None
- A NPTF (standard)
- B Socket weld female
- C Raised face SO flange
- D Flat face SO flange
- E RTJ SO flange
- F Raised face SW flange
- G Flat face SW flange
- H RTJ SW flange
- J Raised face WN flange
- K Flat face WN flange
- L RTJ WN flange
- M Socket weld plugged
- N Socket weld male
- P NPT plugged

PART 4 - PAGE 14

C A G S S

PART 5 - PAGE 15

X X X X X

PENBERTHY SERIES 300 AND 400 OFFSET PATTERN FLAT GLASS GAUGE COCKS
SELECTION GUIDE - PART 4

PART 1 - PAGE 11

320 C C X E

SELECTION GUIDE - PART 4

PART 5 - PAGE 15



PART 2 - PAGE 12

A X C



PART 3 - PAGE 13

A X C A

Example: C A G S S X X X X X

Drain Connection Size

- X None
- C 1/2" (standard)
- E 3/4"
- F 1" (flange only)
- G 1 1/4" (flange only)
- H 1 1/2" (flange only)
- J 2" (flange only)
- K 2 1/2" (flange only)
- L 3" (flange only)

Drain Connection Type

- X None
- A NPTF (standard)
- B Socket weld female
- C Raised face SO flange
- D Flat face SO flange
- E RTJ SO flange
- F Raised face SW flange
- G Flat face SW flange
- H RTJ SW flange
- J Raised face WN flange
- K Flat face WN flange
- L RTJ WN flange
- M Socket weld plugged
- N Socket weld male
- P NPT plugged

Stem Packing Material

- G Grafoil (standard)
- T Teflon®
- V Viton® A

Stem Operation

- S Standard close w/handwheel (standard)
- A Quick close w/lever
- B Quick close w/handwheel
- C Standard close, back seat w/handwheel (400 series only)
- D Quick close, back seat w/lever (400 series only)
- E Quick close, back seat w/handwheel (400 series only)
- F Standard close w/lever

Paint Specification

- X None
- S Standard
- O Offshore

**PENBERTHY SERIES 300 AND 400 OFFSET PATTERN FLAT GLASS GAUGE COCKS
SELECTION GUIDE - PART 5**

PART 1 - PAGE 11

320 C C X E

SELECTION GUIDE - PART 5

Example: X X X X X

- Option 1**
X None
N Vacuum Service Vessel
R 100% Hydro Test Required

- Option 2**
X None
B Pre-heat Welds to 200°F

- Option 3**
X None
B For Steam Service
C For -50°F Service

- Option 4**
X None
B ASME Vertical Ball L-Val Plug
C ASME Ball Checks Omitted

- Option 5**
X None
F USA Origin Only
M Welded Solid Shank Vessel
Y Schedule 160 Nipples

PART 2 - PAGE 12

A X C

PART 3 - PAGE 13

A X C A

PART 4 - PAGE 14

C A G S S

NOTES

Hastelloy® is a registered trademark of Haynes International, Inc.
 Grafoil® is a registered trademark of GrafTech International.
 Monel® is a registered trademark of the Special Metals Corporation.
 Viton® and Teflon® are registered trademarks of the Chemours Company.
 20Cb-3® is a registered trademark of Carpenter Technology Corporation.