

PENBERTHY MODELS RLC AND TLC DIRECT READING LIQUID LEVEL GAUGES

Large chamber flat glass gauges in reflex and transparent styles for turbulent surface or extreme transparent liquids.

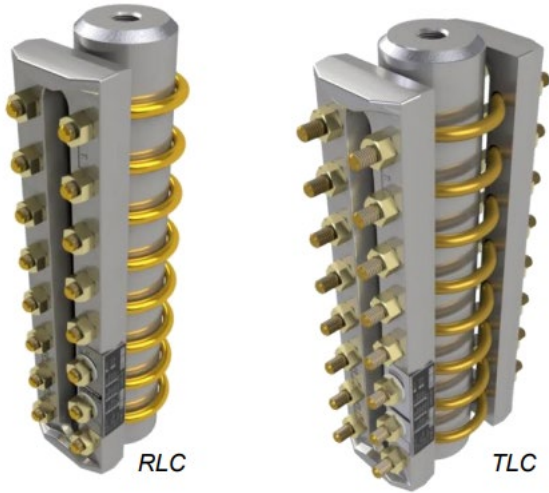

FEATURES

- Reliable, easy to understand level reference.
- Gives users the ability to visually inspect liquid characteristics (transparent style).
- Non-intrusive.
- Operation is independent of most liquid characteristics. Multiple liquids can be processed through the same vessel without concerns for density, surface turbulence, dielectric, conductivity, etc.
- No electrical power required. Provide accurate direct liquid level measurement in remote locations where power is not available. Not affected by power failures.
- Suitable for full vacuum applications.
- Provide a near-unlimited length of measure.
- Optional offshore coating, ideal cost-effective solutions for corrosive offshore environments.
- NACE materials available for sour gas service, both wetted and environmental.
- Optional shields available to prolong glass life in corrosive environments (transparent style only).
- Used for verification of other level instrument technology.
- Recessed gasket seat in chamber and cover.
- Standard carbon steel chamber covers, with optional 316SS for wetted and environmental components.
- Can install with other instrumentation.

GENERAL APPLICATION

Direct reading liquid level measurement applications in petroleum, chemical and general process industries. They are not recommended for steam/water applications. Large chamber design reduces flashing and boiling effects, ensuring accurate level indication.

TECHNICAL DATA

Materials:	Carbon or stainless steel chamber; IFG-5500 gaskets and cushions; tempered Borosilicate
Glass Size:	1 through 9
Visible length:	3-3/4" to 111-1/2" (95 to 2832 mm)
Connections:	End, side or back; threaded, socketweld or flanged
RLC:	2400 psig (165 barg)
TLC:	1200 psig (82 barg)
Temperature*:	-20° to 800°F (-29° to 426°C) For temperatures above 600°F (316°C) Aluminosilicate must be used

*Non-steam/water applications.

PENBERTHY®

16633 Foltz Parkway, Strongsville, OH 44149 USA • Telephone: +440-572-1500
www.PenberthyProcess.com • sales@PenberthyProcess.com

PENBERTHY MODELS RLC AND TLC DIRECT READING LIQUID LEVEL GAUGES

OVERVIEW

OVERVIEW

RLC and TLC gauge models combine forged covers and a large cylindrical chamber and can improve accuracy in determining turbulent vessel liquid levels. In addition to simulating the function of a stilling well and provide a liquid column approximately six times the cross-sectional area of standard gauges, large chamber gauges can provide end connections up to 2" NPTF that can accommodate various instrumentation. Process liquid levels are observed through the glass as it rises and falls in the gauge chamber.

Model RLC – Reflex style gauge

Reflex style gauges have a single vision slot through which light can enter the gauge chamber to determine liquid level. Above the liquid level, glass prisms reflect the surrounding light back to the observer appearing silvery. Below the liquid level, the liquid fills the prisms causing the glass to become relatively transparent, typically appearing dark to the observer. An opaque liquid such as milk would reflect the light directly at the surface of the prisms, where it appears as a solid column of white. The interface between the liquid and gas occurs where the silvery and dark/opaque area intersect.

Model TLC – Transparent style gauge

Transparent style gauges have a vision slot on both sides of the chamber. Light enters the gauge from the side opposite the observer so that both the level of a liquid and its characteristics can be seen. Illuminators are available for use with transparent gauges for easier liquid observation in dark environments.

Transparent gauges may be used for interface applications.

All materials in large chamber gauges conform to ASTM specifications.

REFLEX

(Model RL shown for illustrative purposes only)

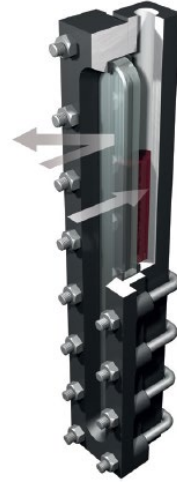

TRANSPARENT

(Model TL shown for illustrative purposes only)

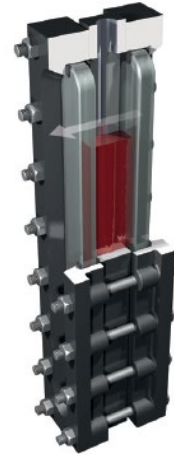

PENBERTHY MODELS RLC AND TLC DIRECT READING LIQUID LEVEL GAUGES
DIMENSIONS

Size No.	Visible Range		Overall Length		Series RLC Reflex Approx. Wt		Series TLC Transparent Approx. Wt	
	in	mm	in	mm	lbs.	Kgs	lbs.	Kgs
11	3.750	95	6.188	157	11	5.0	14	6.4
12	4.750	121	7.188	183	13	5.9	17	7.7
13	5.750	146	8.188	208	15	6.8	19	8.6
14	6.750	171	9.188	233	17	7.7	21	9.5
15	7.875	200	10.313	262	18	8.2	23	10.5
16	9.125	232	11.563	294	20	9.1	26	11.8
17	10.250	260	12.688	322	22	10.0	29	13.2
18	11.875	302	14.313	364	25	11.4	32	14.5
19	12.625	321	15.063	383	26	11.8	34	15.5
23	13.000	330	15.438	392	27	12.3	36	16.4
24	15.000	381	17.438	443	31	14.1	40	18.2
25	17.250	438	19.688	500	34	15.5	45	20.5
26	19.750	502	22.188	564	39	17.7	50	22.7
27	22.000	559	24.438	621	43	19.5	55	25.0
28	25.250	641	27.688	703	48	21.8	62	28.2
29	26.750	679	29.188	741	51	23.2	65	29.5
36	30.375	772	32.813	833	57	25.9	74	33.6
37	33.750	857	36.188	919	63	28.6	82	37.3
38	38.625	981	41.063	1043	71	32.3	92	41.8
39	40.875	1038	43.313	1100	75	34.1	97	44.1
47	45.500	1156	47.938	1218	84	38.2	108	49.1
48	52.000	1321	54.438	1383	95	43.2	122	55.5
49	55.000	1397	57.438	1459	99	45.0	129	58.6
57	57.250	1454	59.688	1516	104	47.3	135	61.4
58	65.375	1661	67.813	1722	118	53.6	153	69.5
59	69.125	1756	71.563	1818	123	55.9	161	73.2
68	78.750	2000	81.188	2062	141	64.1	183	83.2
69	83.250	2115	85.688	2176	148	67.3	192	87.3
78	92.125	2340	94.563	2402	164	74.5	213	96.8
79	97.375	2473	99.813	2535	172	78.2	224	101.8
88	105.500	2680	107.938	2742	187	85.0	243	110.5
89	111.500	2832	113.938	2894	196	89.1	256	116.4

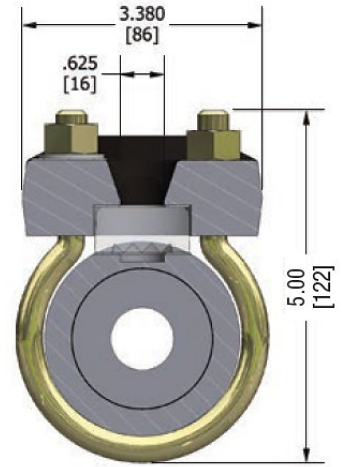

Series RLC Reflex

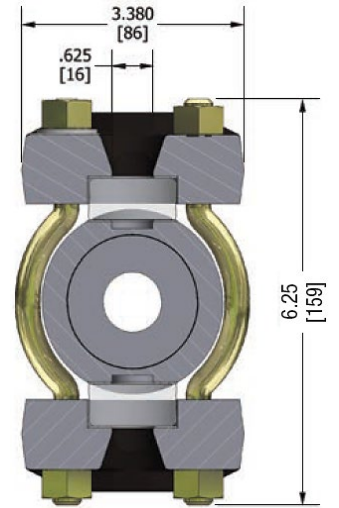

Series TLC Transparent

PENBERTHY MODELS RLC AND TLC DIRECT READING LIQUID LEVEL GAUGES
PRESSURE/TEMPERATURE RATINGS – MODEL RLC & TLC

Pressure / Temperature Ratings, PSI

Temperature		RLC REFLEX GAUGE								
		Glass Size								
°F	°C	1	2	3	4	5	6	7	8	9
100	38	2400	2250	2100	1940	1800	1640	1500	1340	1200
200	93	2220	2090	1950	1810	1670	1540	1400	1260	1130
300	149	2050	1920	1800	1680	1540	1430	1300	1180	1060
400	204	1860	1750	1640	1530	1420	1320	1200	1100	1000
500	260	1690	1600	1500	1400	1300	1210	1110	1010	920
600	316	1520	1430	1350	1260	1180	1100	1010	920	850
For temperatures above 600°F (316°C) Aluminosilicate Glass must be used.										
700	371	1340	1270	1200	1130	1060	990	920	850	780
800	427	1170	1110	1060	1000	940	880	830	770	710

Not recommended for steam service.

Temperature		TLC TRANSPARENTGAUGE								
		Glass Size								
°F	°C	1	2	3	4	5	6	7	8	9
100	38	1200	1110	1020	930	850	760	680	590	500
200	93	1080	1000	920	840	760	680	600	530	450
300	149	960	890	830	750	680	620	540	470	400
400	204	850	790	720	670	600	540	480	420	360
500	260	730	680	630	570	520	470	420	360	310
600	316	620	570	530	480	440	400	360	310	270
For temperatures above 600°F (316°C) Aluminosilicate Glass must be used.										
700	371	500	470	430	400	360	330	290	260	220
800	427	390	360	310	310	290	260	230	210	180

Not recommended for steam service.

Pressure / Temperature Ratings, BarG

Temperature		RLC REFLEX GAUGE								
		Glass Size								
°F	°C	1	2	3	4	5	6	7	8	9
100	38	165.5	155.1	144.8	133.8	124.1	113.1	103.4	92.4	82.7
200	93	153.1	144.1	134.4	124.8	115.1	106.2	96.5	86.9	77.9
300	149	141.3	132.4	124.1	115.8	106.2	98.6	89.6	81.4	73.1
400	204	128.2	120.7	113.1	105.5	97.9	91.0	82.7	75.8	68.9
500	260	116.5	110.3	103.4	96.5	89.6	83.4	46.5	69.6	63.4
600	316	104.8	98.6	93.1	86.9	81.4	75.8	69.6	63.4	58.6
For temperatures above 600°F (316°C) Aluminosilicate Glass must be used.										
700	371	92.4	87.6	82.7	77.9	73.1	68.3	63.4	58.6	53.8
800	427	80.7	76.5	73.1	68.9	64.8	60.7	57.2	53.1	49.0

Not recommended for steam service.

Temperature		TLC TRANSPARENTGAUGE								
		Glass Size								
°F	°C	1	2	3	4	5	6	7	8	9
100	38	82.7	76.5	70.3	64.1	58.6	52.4	46.9	40.7	34.5
200	93	74.5	68.9	63.4	57.9	52.4	46.9	41.4	36.5	31.0
300	149	66.2	61.4	57.2	51.7	46.9	42.7	37.2	32.4	27.6
400	204	58.6	54.5	49.6	46.2	41.4	37.2	33.1	29.0	24.8
500	260	50.3	46.9	43.4	39.3	35.9	32.4	29.0	24.8	21.4
600	316	42.7	39.3	36.5	33.1	30.3	27.6	24.8	21.4	18.6
For temperatures above 600°F (316°C) Aluminosilicate Glass must be used.										
700	371	34.5	32.4	29.6	27.6	24.8	22.8	20.0	17.9	15.2
800	427	26.9	24.8	23.4	21.4	20.0	17.9	15.9	14.5	12.4

Not recommended for steam service.

PENBERTHY MODELS RLC AND TLC DIRECT READING LIQUID LEVEL GAUGES
MATERIAL SPECIFICATIONS

Description	Carbon Steel	316SS Wetted	All 316SS
Cover	A105	A105	A276
Chamber	A36		A276
Stud	A193 Gr.B7 (Yellow Zn Plated)		A193 Gr.B8M
Nut	A194 2H (Yellow Zn Plated)		A194 Gr.8M
Seal Gasket Cushion Gasket	Garlock IFG5500 Standard Optoinal Gore Gr (ePTFE) or Grafoil		
Shield	None Standard Optional Mica or Kel-F		
Glass	Reflex or Transparent		
U-Bolt	A193 Gr.B7 (Yellow Zn Plated)	A193 Gr.B8M	

Contact Factory for special alloy chambers, covers, bolting, gaskets

Chamber

Carbon Steel -20°F (-28°C)
 316 Stainless Steel -325°F (-198°C)

Optional Accessories

- Illuminator
- Non-Frost Extensions
- Spring Washers
- Cold Insulation
- Heat Tracing
- Support Brackets
- Scales

PENBERTHY MODELS RLC AND TLC DIRECT READING LIQUID LEVEL GAUGES
MODEL STRUCTURE

Selection Guide

PART 2 - PAGE 7

Example:	01	RLC	4	S	S	C	W	E	B	X	F	F	6	S	00825	T
Number of Sections																
01	1 Section															
02	2 Section															
03	3 Section															
04	4 Section															
05	5 Section															
06	6 Section															
07	7 Section															
08	8 Section															
Gauge Type																
RLC	Large Chamber Reflex Gauge															
TLC	Large Chamber Transparent Gauge															
Glass Size																
1	Size 1															
2	Size 2															
3	Size 3															
4	Size 4															
5	Size 5															
6	Size 6															
7	Size 7															
8	Size 8															
9	Size 9															
Wetted Parts Material (Chamber)																
C	Carbon steel (Standard)															
S	316/316L Stainless steel															
Cover Material																
C	Carbon steel (Standard)															
S	316/316L Stainless steel															
Bolting Material																
C	STL A193 Gr.B7 (Yellow Zn Plated)/A194 2H (standard)															
S	SST NACE A193 B8M / A194 8M															
NACE MR-01-75 &/OR MR-01-03																
X	None															
W	NACE wetted															
E	Environmental															
End Connection Size																
C	1/2" (Standard)															
E	3/4"															
F	1"															
H	1-1/2" (flange only)															
J	2" (flange only)															

PART 3 - PAGE 8

S	S	X	X	X	D	X
---	---	---	---	---	---	---



PENBERTHY MODELS RLC AND TLC DIRECT READING LIQUID LEVEL GAUGES
MODEL STRUCTURE

PART 1 - PAGE 6

SELECTION GUIDE - PART 2

PART 3 - PAGE 8

01	RLC	4	S	S	C	W	E	Example:	B	X	F	F	6	S	00825	T	S	S	X	X	X	D	X				
								End Connection Type																			
								B	NPT Female (Standard)																		
								D	Socketweld Female																		
								F	Plugged																		
								G	Socketweld Male																		
								N	Raised SO																		
								End Connection Pressure Class																			
								X	None																		
								1	150#																		
								3	300#																		
								6	600#																		
								9	J900#																		
								F	1500#																		
								T	2500#																		
								Side Connection Size																			
								X	None																		
								C	1/2" (standard)																		
								E	3/4"																		
								F	1" (Flange Only)																		
								H	1-1/2" (Flange Only)																		
								J	2" (Flange Only)																		
								Side Connection Type																			
								X	None				S	Raised Face SW													
								B	NPT Female (Standard)				T	Flat Face SW													
								D	Socketweld Female				U	RTJ SW													
								N	Raised Face SO				V	Raised Face WN													
								P	Flat Face SO				W	Flat Face WN													
								R	RTJ SO				Y	RTJ WN													
								Side Pressure Class																			
								X	None																		
								1	150F#																		
								3	300F#																		
								6	600F#																		
								9	900F#																		
								F	1500F#																		
								T	2500F#																		
								Side Connection Location																			
								X	None																		
								S	Right Side Connected (Standard)																		
								L	Left Side Connected																		
								B	Back Connected																		
								Connection Dimensions																			
								XXXXX	None																		
								00000	Inches (first 3 digits = number of whole inches, last 2 digits = fraction of an inch in hundredths)																		
								Gasket Material																			
								S	Grafoil® /SS Insert																		
								T	Gore GR (ePTFE)																		
								A	Garlock® IFG-5500 (Standard)																		
								P	PCTFE (KEL-F)																		



PART 1 - PAGE 6

SELECTION GUIDE - PART 3

01 RLC 4 S S C W E Example: S S X X X X X

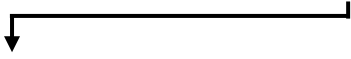

PART 2 - PAGE 7

B X F F 6 S 00825 T

- Cushion Material**
 - S Grafoil® /SS Insert
 - A Garlock® IFG-5500 (Standard)
- Paint Specification**
 - X None
 - S Standard
 - O Offshore Paint
- Option 1 Description**
 - X None
 - B 1 Welded Support Bracket
 - C 2 Welded Support Bracket
 - D 3 Welded Support Bracket
 - K Belleville Washer
- Option 2 Description**
 - X None
- Option 3 Description**
 - X None
 - B Mica Shields V2/V4 (.005-.007" thick)
 - C PCTFE Shields (KEL-F)
 - D Mica Shields V2/V4 (.009-.012" thick)
- Option 4 Description**
 - X None
 - N Aluminosilicate Glass
- Option 5 Description**
 - X None
 - C Material Origin Restriction (USA, Canada, Western Europe)



16633 Foltz Parkway, Strongsville, OH 44149 USA • Telephone: +440-572-1500
www.PenberthyProcess.com • sales@PenberthyProcess.com