

# PENBERTHY MODELS RM AND TM DIRECT READING LIQUID LEVEL GAUGES

Medium pressure flat glass gauges in reflex and transparent styles



RM



TM

## GENERAL APPLICATION

Medium pressure gauges are designed to be used in direct reading liquid level measurement for medium pressure tank applications in the petroleum, chemical, natural gas and general process industries

## TECHNICAL DATA

Materials: Carbon, low-temp carbon or stainless steel cover and chamber; IFG-5500® gaskets and cushions; Tempered Borosilicate glass rated to 600°F (316°C)

Glass size: 1 through 9

Visible length: 3¾" to 139¾" (95 to 3550 mm)

Connections: End or side; threaded, socketweld or flanged

Pressure Ratings:  
(max)

RM: Glass size 1: 3000 psig (207 barg)  
Glass size 9: 2250 psig (155 barg)

TM: Glass size 1: 2500 psig (172 barg)  
Glass size 9: 1000 psig (69 barg)

Temperature: -20 to 600°F (-29 to 316°C)

## FEATURES

- Reliable, easy to understand level reference.
- Gives users the ability to inspect liquid characteristics visually (transparent style).
- Non-intrusive
- Operation is independent of most liquid characteristics. Multiple liquids can be processed through the same vessel without concerns for density, surface turbulence, dielectric conductivity etc.
- No electrical power required. Provide accurate direct liquid level measurement in remote locations where power is not available. Not affected by power failures.
- Suitable for full vacuum applications.
- Provide a near-unlimited length of measure.
- Optional offshore coating 2600 protection; ideal cost-effective solution for corrosive offshore environments.
- NACE materials available for sour gas service both wetted and environmental.
- Used for verification of other level instrument technology.
- Optional recessed gasket chamber available.
- Standard flat gasket seat allows easy removal of gasket residue during rebuild.
- Optional shields available to prolong glass life in corrosive environments (transparent style only).
- Cross ties between vision slots in transparent style gauges provide higher strength chamber due to reduction of unsupported beam length

# PENBERTHY®

16633 Foltz Parkway, Strongsville, OH 44149 USA • Telephone: +440-572-1500  
[www.PenberthyProcess.com](http://www.PenberthyProcess.com) • [sales@PenberthyProcess.com](mailto:sales@PenberthyProcess.com)

**OVERVIEW**

RM and TM gauges provide optimum versatility and can be used for most offshore applications and in other corrosive environments. Process liquid levels are observed through the glass as it rises and falls in the gauge chamber. Optional materials are available for temperature ranges -325 to 800°F (-198 to 427°C) - see Application Report 2780.1

**Models RLC – Reflex style gauge**

Reflex style gauges have a single vision slot through which light can enter the gauge chamber to determine liquid level. Above the liquid level, glass prisms reflect the surrounding light back to the observer appearing silvery. Below the liquid level, the liquid fills the prisms causing the glass to become relatively transparent, typically appearing dark to the observer. An opaque liquid such as milk would reflect the light directly at the surface of the prisms, where it appears as a solid column of white. The interface between the liquid and gas occurs where the silvery and dark/opaque area intersect.

Model RM gauges may also be used for low pressure steam/water applications and meet ASME Section VIII Boiler Code.

Model RMR are reflex gauges with a recessed gasket chamber.

**Model TLC – Transparent style gauge**

Transparent style gauges have a vision slot on both sides of the chamber. Light enters the gauge from the side opposite the observer so that both the level of a liquid and its characteristics can be seen. Illuminators are available for use with transparent gauges for easier liquid observation in dark environments. Transparent gauges are also available with optional Aluminosilicate glass rated to maximum 800°F (427°C).

TM gauges may be used for interface applications.

Model TMR are transparent gauges with a recessed gasket chamber.

**REFLEX**

(Model RL shown for illustrative purposes only)



**TRANSPARENT**

(Model TL shown for illustrative purposes only).



**PENBERTHY MODELS RM AND TM DIRECT READING LIQUID LEVEL GAUGES**

**DIMENSIONS – End Connected**

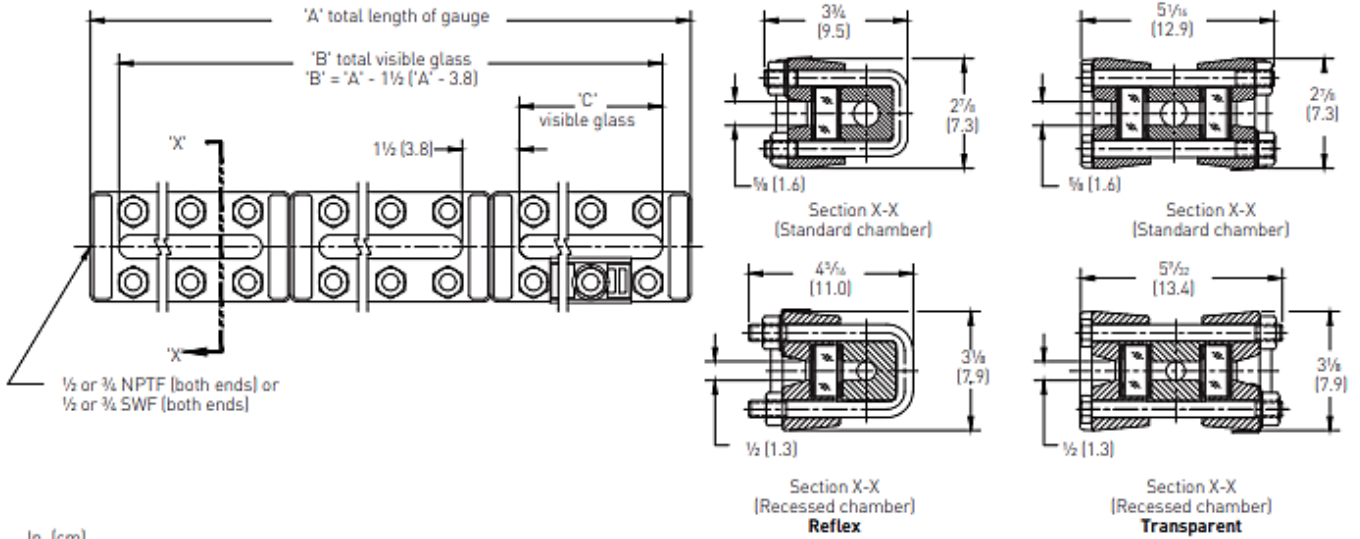

In. (cm)

**DIMENSIONS - END CONNECTED**

Glass size	Dim 'C' in inches (cm)	Dimension 'A' in inches (cm)										Quantity per section (reflex)		Quantity per section (transparent)		
		Number of sections										Bolt	Nut	Bolt	Nut	
		1	2	3	4	5	6	7	8	9	10					
1	3.75 (9.5)	5.25 (13.3)											3	6	6	6
2	4.75 (12.1)	6.25 (15.9)											3	6	6	6
3	5.75 (14.6)	7.25 (18.4)											4	8	8	8
4	6.75 (17.1)	8.25 (21.0)	16.50 (41.9)										4	8	8	8
5	7.87 (20.0)	9.37 (23.8)	18.75 (47.6)										5	10	10	10
6	9.12 (23.2)	10.62 (27.0)	21.25 (54.0)	31.87 (81.0)									6	12	12	12
7	10.25 (26.0)	11.75 (29.8)	23.50 (59.7)	35.25 (89.5)	47.00 (119.4)	58.75 (149.2)							6	12	12	12
8	11.87 (30.2)	13.37 (34.0)	26.75 (67.9)	40.12 (101.9)	53.50 (135.9)	66.87 (169.9)	80.25 (203.8)	93.62 (237.8)	107.00 (271.8)	120.37 (305.8)	133.75 (339.7)		7	14	14	14
9	12.62 (32.1)	14.12 (35.9)	28.25 (71.8)	42.37 (107.6)	56.50 (143.5)	70.62 (179.4)	84.75 (215.3)	98.87 (251.1)	113.00 (287.0)	127.12 (322.9)	141.25 (358.8)		7	14	14	14

**NOTE**

For 3/4" NPT and 3/4" SWF add 3/4" (19 mm) to dimension 'A' on RMR and TMR Series only.



# PENBERTHY MODELS RM AND TM DIRECT READING LIQUID LEVEL GAUGES

## DIMENSIONS - MODELS RM/TM SIDE CONNECTED

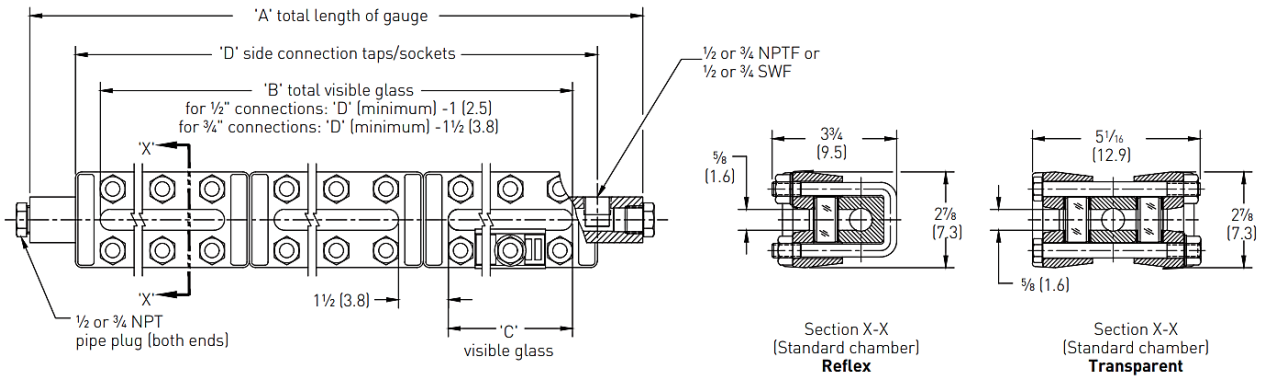

In. (cm)

### DIMENSIONS - SIDE CONNECTED

Glass size		Max. and min. dimension 'D' in inches (cm) for 1/2" NPT/socketweld connections									
		Centers available in 1/8" (0.3 cm) increments between max. and min. / Standard side connection is to the right of the gauge vision									
		Number of sections									
		1	2	3	4	5	6	7	8	9	10
1	min.	4.75 (12.1)									
	max.	7.62 (19.4)									
2	min.	5.75 (14.6)									
	max.	8.62 (21.9)									
3	min.	6.75 (17.1)									
	max.	9.62 (24.4)									
4	min.	7.75 (19.7)	16.00 (40.6)								
	max.	10.75 (27.3)	20.12 (51.1)								
5	min.	8.87 (22.5)	18.25 (46.4)								
	max.	12.00 (30.5)	22.62 (57.5)								
6	min.	10.12 (25.7)	20.75 (52.7)	31.37 (79.7)							
	max.	13.12 (33.3)	24.87 (63.2)	36.62 (93.0)							
7	min.	11.25 (28.6)	23.00 (58.4)	34.75 (88.3)	46.50 (118.1)	58.25 (148.0)					
	max.	14.75 (37.5)	28.12 (71.4)	41.25 (104.8)	54.87 (139.4)	68.25 (173.4)					
8	min.	12.87 (32.7)	26.25 (66.7)	39.62 (100.6)	53.00 (134.6)	66.37 (168.6)	79.75 (202.6)	93.12 (236.5)	106.50 (270.5)	119.87 (304.5)	133.25 (338.5)
	max.	15.50 (39.4)	29.62 (75.2)	43.75 (111.1)	57.87 (147.0)	72.00 (182.9)	84.12 (213.7)	98.25 (249.6)	112.37 (285.4)	126.50 (321.3)	140.62 (357.2)
9	min.	13.62 (34.6)	27.75 (70.5)	41.87 (106.4)	56.00 (142.2)	70.12 (178.1)	84.25 (214.0)	98.37 (249.9)	112.50 (285.8)	126.62 (321.6)	140.75 (357.5)
	max.	17.87 (45.4)	33.25 (84.5)	48.37 (122.9)	60.12 (152.7)	81.62 (207.3)	93.00 (236.2)	106.37 (270.2)	119.75 (304.2)	133.12 (338.1)	146.50 (372.1)

### NOTES

- For minimum 1/4" NPT/socketweld connections - add 1/2 (1.3) to dimension 'D' shown above.
- For maximum 3/4" NPT/socketweld connections - subtract 3/4 (1.9) from dimension 'D' shown above.
- Consult factory for minimum front or back connections

### DIMENSIONS - SIDE CONNECTED

Glass size	Dim 'C' in inches (cm)	Dimension 'A' in inches (cm) 1/2" and 3/4" NPT/socketweld connections										Quantity per section (reflex)		Quantity per section (transparent)	
		Number of sections										Bolt	Nut	Bolt	Nut
		1	2	3	4	5	6	7	8	9	10				
1	3.75 (9.5)	10.37 (26.4)										3	6	6	6
2	4.75 (12.1)	11.37 (28.9)										3	6	6	6
3	5.75 (14.6)	12.37 (31.4)										4	8	8	8
4	6.75 (17.1)	13.50 (34.3)	22.87 (58.1)									4	8	8	8
5	7.87 (20.0)	14.75 (37.5)	25.37 (64.5)									5	10	10	10
6	9.12 (23.2)	15.87 (40.3)	27.62 (70.2)	39.37 (100.0)								6	12	12	12
7	10.25 (26.0)	17.50 (44.5)	30.87 (78.4)	44.25 (112.4)	57.62 (146.4)	71.00 (180.3)						6	12	12	12
8	11.87 (30.2)	18.25 (46.4)	32.37 (82.2)	46.50 (118.1)	60.62 (154.0)	74.75 (189.9)	***	***	***	***	***	7	14	14	14
9	12.62 (32.1)	20.62 (52.4)	36.00 (91.5)	51.12 (129.9)	62.87 (159.7)	84.37 (214.3)	***	***	***	***	***	7	14	14	14

### NOTES

- \*\*\* For 1/2" NPT or socketweld connections: Dimension 'D' + 2 3/4 (7.0)
- \*\*\* For 3/4" NPT or socketweld connections: Dimension 'D' + 3 1/2 (8.9)



**PENBERTHY MODELS RM AND TM DIRECT READING LIQUID LEVEL GAUGES**  
**DIMENSIONS - MODELS RMR/TMR SIDE CONNECTED**

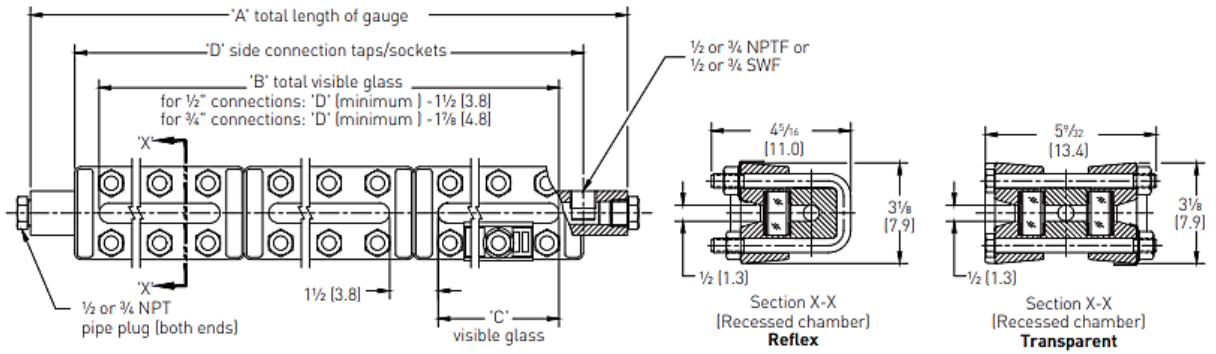

In. (cm)

**DIMENSIONS - SIDE CONNECTED**

Max. and min. dimension 'D' in inches (cm) for 1/2" NPT/socketweld connections											
Centers available in 1/8" (0.3 cm) increments between max. and min. / Standard side connection is to the right of the gauge vision											
Glass size		Number of sections									
		1	2	3	4	5	6	7	8	9	10
1	min.	5.25 (13.3)									
	max.	7.62 (19.4)									
2	min.	6.25 (15.9)									
	max.	8.62 (21.9)									
3	min.	7.25 (18.4)									
	max.	9.62 (24.4)									
4	min.	8.25 (21.0)	16.50 (41.9)								
	max.	10.75 (27.3)	20.12 (51.1)								
5	min.	9.37 (23.8)	18.75 (47.6)								
	max.	12.00 (30.5)	22.62 (57.5)								
6	min.	10.62 (27.0)	21.25 (54.0)	31.87 (81.0)							
	max.	13.12 (33.3)	24.87 (63.2)	36.62 (93.0)							
7	min.	11.75 (29.8)	23.50 (59.7)	35.25 (89.5)	47 (119.4)	58.75 (149.2)					
	max.	14.75 (37.5)	28.12 (71.4)	41.25 (104.8)	54.87 (139.4)	68.25 (173.4)					
8	min.	13.37 (34.0)	26.75 (67.9)	40.12 (101.9)	53.50 (135.9)	66.87 (169.9)	80.25 (203.8)	93.62 (237.8)	107.00 (271.8)	120.37 (305.7)	133.75 (339.7)
	max.	15.50 (39.4)	29.62 (75.2)	43.75 (111.1)	57.87 (147.0)	72.00 (182.9)	84.62 (214.9)	98.75 (250.8)	112.87 (286.7)	127.00 (322.6)	141.12 (358.5)
9	min.	14.12 (35.9)	28.25 (71.8)	42.37 (107.6)	56.50 (143.5)	70.62 (179.4)	84.75 (215.3)	98.87 (251.1)	113.00 (287.0)	127.12 (322.9)	141.25 (358.8)
	max.	17.87 (45.4)	33.25 (84.5)	48.37 (122.9)	60.12 (152.7)	81.62 (207.3)	93.50 (237.5)	106.87 (271.5)	120.25 (305.4)	133.62 (339.4)	147.00 (373.4)

**NOTES**

- For minimum 3/4" NPT/socketweld connections - add 1/4 (0.6) to dimension 'D' shown above.
- For maximum 3/4" NPT/socketweld connections - subtract 3/4 (1.9) from dimension 'D' shown above.
- Consult factory for minimum front or back connections

**DIMENSIONS - SIDE CONNECTED**

Glass size	Dim 'C' in inches (cm)	Dimension 'A' in inches (cm) 1/2" and 3/4" NPT/socketweld connections	Quantity per section (reflex)		Quantity per section (transparent)	
			Bolt	Nut	Bolt	Nut
1	3.75 (9.5)	***	3	6	6	6
2	4.75 (12.1)	***	3	6	6	6
3	5.75 (14.6)	***	4	8	8	8
4	6.75 (17.1)	***	4	8	8	8
5	7.87 (20.0)	***	5	10	10	10
6	9.12 (23.2)	***	6	12	12	12
7	10.25 (26.0)	***	6	12	12	12
8	11.87 (30.2)	***	7	14	14	14
9	12.62 (32.1)	***	7	14	14	14

**NOTES**

- \*\*\* For 1/2" NPT or socketweld connections: Dimension 'D' + 2 3/4 (7.0)
- \*\*\* For 3/4" NPT or socketweld connections: Dimension 'D' + 3 1/2 (8.9)



# PENBERTHY MODELS RM AND TM DIRECT READING LIQUID LEVEL GAUGES PRESSURE/TEMPERATURE RATINGS - MODELS RM/RMR

## PRESSURE/TEMPERATURE RATINGS using standard gasket material<sup>(1)</sup>

Glass size	Max. working pressure psig (kPa) at temperatures up to:						
	100°F (38°C)	200°F (93°C)	250°F (121°C)	300°F (149°C)	400°F (204°C)	500°F (260°C)	600°F (316°C)
1	3000 (20680)	2900 (19990)	2850 (19650)	2800 (19310)	2690 (18550)	2500 (17240)	2220 (15310)
2	2910 (20060)	2820 (19440)	2770 (19100)	2720 (18750)	2600 (17930)	2420 (16690)	2150 (14820)
3	2820 (19440)	2720 (18750)	2675 (18440)	2625 (18100)	2530 (17440)	2350 (16200)	2080 (14340)
4	2725 (18790)	2640 (18200)	2600 (17930)	2560 (17650)	2460 (16960)	2270 (15650)	2040 (14070)
5	2630 (18130)	2540 (17510)	2500 (17240)	2460 (16960)	2360 (16270)	2190 (15100)	1950 (13440)
6	2535 (17480)	2450 (16890)	2405 (16580)	2360 (16270)	2270 (15650)	2110 (14550)	1875 (12930)
7	2440 (16820)	2360 (16270)	2320 (16000)	2280 (15720)	2190 (15100)	2030 (14000)	1805 (12440)
8	2345 (16170)	2270 (15650)	2230 (15380)	2190 (15100)	2110 (14550)	1960 (13510)	1740 (12000)
9	2250 (15510)	2180 (15030)	2140 (14750)	2100 (14480)	2020 (13930)	1870 (12890)	1660 (11450)

## PRESSURE/TEMPERATURE RATINGS using standard gasket material<sup>(1)</sup> and steel MR0175/MR0103 NACE bolting

Glass Size	Max. working pressure psig (kPa) at temperatures up to:						
	100°F (38°C)	200°F (93°C)	250°F (121°C)	300°F (149°C)	400°F (204°C)	500°F (260°C)	600°F (316°C)
1	2700 (18620)	2610 (18000)	2565 (17680)	2520 (17370)	2420 (16690)	2250 (15510)	2000 (13790)
2	2620 (18060)	2540 (17510)	2495 (17200)	2450 (16890)	2340 (16130)	2180 (15030)	1935 (13340)
3	2540 (17510)	2450 (16890)	2410 (16620)	2365 (16310)	2275 (15690)	2115 (14580)	1870 (12890)
4	2455 (16930)	2375 (16370)	2340 (16130)	2305 (15890)	2215 (15270)	2045 (14100)	1835 (12650)
5	2365 (16310)	2285 (15750)	2250 (15510)	2215 (15270)	2125 (14650)	1970 (13580)	1755 (12100)
6	2280 (15720)	2205 (15200)	2165 (14930)	2125 (14650)	2045 (14100)	1900 (13100)	1690 (11650)
7	2195 (15130)	2125 (14650)	2090 (14410)	2050 (14130)	1970 (13580)	1825 (12580)	1625 (11200)
8	2110 (14550)	2045 (14100)	2005 (13820)	1970 (13580)	1900 (13100)	1765 (12170)	1565 (10790)
9	2025 (13960)	1960 (13510)	1925 (13270)	1890 (13030)	1820 (12550)	1685 (11620)	1495 (10310)

## PRESSURE/TEMPERATURE RATINGS using standard gasket material<sup>(1)</sup> and stainless steel MR0175/MR0103 NACE bolting

Glass size	Max. working pressure psig (kPa) at temp. up to:
	100°F (38°C)
1	1930 (13310)
2	1550 (10690)
3	1730 (11930)
4	1485 (10240)
5	1605 (11070)
6	1670 (11510)
7	1495 (10310)
8	1515 (10450)
9	1425 (9820)

### NOTE

- Optional gasket material may result in a derated maximum pressure for the gauge.

**PENBERTHY MODELS RM AND TM DIRECT READING LIQUID LEVEL GAUGES  
PRESSURE/TEMPERATURE RATINGS - MODELS TM/TMR**

**PRESSURE/TEMPERATURE RATINGS using standard gasket material<sup>(1)</sup>**

Glass size	Max. working pressure psig (kPa) at temperatures up to:						
	100°F (38°C)	200°F (93°C)	250°F (121°C)	300°F (149°C)	400°F (204°C)	500°F (260°C)	600°F (316°C)
1	2500 (17240)	2420 (16690)	2380 (16410)	2340 (16130)	2240 (15440)	2080 (14340)	1850 (12760)
2	2315 (15960)	2250 (15510)	2210 (15240)	2170 (14960)	2090 (14410)	1940 (13380)	1720 (11860)
3	2130 (14690)	2060 (14200)	2025 (13960)	1990 (13720)	1910 (13170)	1770 (12200)	1575 (10860)
4	1940 (13380)	1875 (12930)	1845 (12720)	1810 (12480)	1740 (12000)	1620 (11170)	1435 (9890)
5	1750 (12070)	1690 (11650)	1660 (11450)	1630 (11240)	1570 (10820)	1460 (10070)	1295 (8930)
6	1565 (10790)	1510 (10410)	1485 (10240)	1460 (10070)	1400 (9650)	1305 (9000)	1160 (8000)
7	1375 (9480)	1330 (9170)	1305 (9000)	1280 (8830)	1230 (8480)	1145 (7890)	1015 (7000)
8	1190 (8200)	1150 (7930)	1130 (7790)	1110 (7650)	1065 (7340)	990 (6830)	880 (6070)
9	1000 (6890)	970 (6690)	955 (6580)	935 (6450)	895 (6170)	835 (5760)	740 (5100)

**PRESSURE/TEMPERATURE RATINGS using standard gasket material<sup>(1)</sup> and steel MR0175/MR0103 NACE bolting**

Glass Size	Max. working pressure psig (kPa) at temperatures up to:						
	100°F (38°C)	200°F (93°C)	250°F (121°C)	300°F (149°C)	400°F (204°C)	500°F (260°C)	600°F (316°C)
1	2250 (15510)	2180 (15030)	2140 (14750)	2105 (14510)	2015 (13890)	1870 (12890)	1665 (11480)
2	2085 (14380)	2025 (13960)	1990 (13720)	1955 (13480)	1880 (12960)	1745 (12030)	1550 (10690)
3	1915 (13200)	1855 (12790)	1825 (12580)	1790 (12340)	1720 (11860)	1595 (11000)	1420 (9790)
4	1745 (12030)	1690 (11650)	1660 (11450)	1630 (11240)	1565 (10790)	1460 (10070)	1290 (8890)
5	1575 (10860)	1520 (10480)	1495 (10310)	1465 (10100)	1415 (9760)	1315 (9070)	1165 (8030)
6	1410 (9720)	1360 (9380)	1335 (9200)	1315 (9070)	1260 (8690)	1175 (8100)	1045 (7200)
7	1240 (8550)	1195 (8240)	1175 (8100)	1150 (7930)	1105 (7620)	1030 (7100)	915 (6310)
8	1070 (7380)	1035 (7140)	1015 (7000)	1000 (6890)	960 (6620)	890 (6140)	790 (5450)
9	900 (6210)	875 (6030)	860 (5930)	840 (5790)	805 (5550)	750 (5170)	665 (4580)

**PRESSURE/TEMPERATURE RATINGS using standard gasket material<sup>(1)</sup> and stainless steel MR0175/MR0103 NACE bolting**

Glass size	Max. working pressure psig (kPa) at temp. up to:	
	100°F (38°C)	
1	1880 (12960)	
2	1510 (10410)	
3	1685 (11620)	
4	1450 (10000)	
5	1565 (10790)	
6	1565 (10790)	
7	1375 (9480)	
8	1190 (8200)	
9	1000 (6890)	

**PRESSURE/TEMPERATURE RATINGS using standard gasket material<sup>(1)</sup> and aluminosilicate glass**

Glass size	Max. working pressure psig (kPa) at temp. up to:		
	600°F (316°C)	750°F (399°C)	800°F (427°C)
1	1850 (12760)	1420 (9790)	1280 (8830)
2	1720 (11860)	1325 (9140)	1190 (8200)
3	1575 (10860)	1210 (8340)	1085 (7480)
4	1435 (9890)	1100 (7580)	990 (6830)
5	1295 (8930)	995 (6860)	890 (6140)
6	1160 (8000)	885 (6100)	795 (5480)
7	1015 (7000)	780 (5380)	700 (4830)
8	880 (6070)	675 (4650)	605 (4170)
9	740 (5100)	565 (3900)	505 (3480)

**NOTE**

- Optional gasket material may result in a derated maximum pressure for the gauge.

**PENBERTHY MODELS RM AND TM DIRECT READING LIQUID LEVEL GAUGES**  
**MATERIAL SPECIFICATIONS – MODELS RM/TM**

**MODELS RM AND TM MATERIALS**

Ref. No.	Description	Standard materials					Optional materials
		Carbon steel to -20°F	STS wetted to -20°F	STS Construction to -325°F	Sour gas service to -20°F	Low-temp steel to -50°F	
1	Cover	size 1 and 2	ASTM A216 Carbon steel (cast) Gr. WCB	ASTM A351 316/316L STS (cast) Gr. CF3M	ASTM A216 Carbon steel (cast) Gr. WCB	ASTM A352 Carbon steel (cast) GR. LCB	ASTM A351 304/304L STS Gr. CF3 ASTM A182 Gr. F51 Duplex 2205 STS ASTM A494 Hastelloy B® Gr. N-12MV ASTM A352 Carbon steel Gr. LCB ASTM A743 Alloy 20 Gr. CN7M ASTM B564 Monel® 400 N04400 ASTM A494 Hastelloy C® Gr. CW12MW ASTM A123 galvanized steel
		size 3 - 9	ASTM A105 (forged) Carbon steel		ASTM A105 (forged) Carbon steel	ASTM A350 Carbon steel (forged) Gr. LF2 CL 1	ASTM A276 304/304L STS ASTM A276 Duplex 2205 STS ASTM B164 Monel® 400 ASTM B463 Alloy 20 (CARP 20 Cb3)® ASTM B335 Hastelloy B® ASTM B575 Hastelloy C® 276 ASTM A123 galvanized Steel
2	Chamber	ASTM A105 (forged) Carbon steel	ASTM A276 316/316L STS		ASTM A105 (forged) Carbon steel per NACE MR0175 and/OR MR0103	ASTM A350 Gr. LF2 Carbon steel or ASTM A516 Gr. 70/S5 -50°F Carbon steel	ASTM A276 304/304L STS ASTM A276 Duplex 2205 STS ASTM B164 Monel® 400 ASTM B463 Alloy 20 (CARP 20 Cb3)® ASTM B335 Hastelloy B® ASTM B575 Hastelloy C® 276 ASTM A123 galvanized Steel
4	Nut	ASTM A194 Carbon steel Gr. 2 or 2H	ASTM A194 316 STS Gr. 8M		ASTM A194 Carbon steel Gr. 2 or 2H	ASTM A194 316 STS Gr. 8M	ASTM A153 galvanized steel ASTM A194 Gr. 2HM
7	Gasket	Garlock® IFG-5500					Grafoil® Gr. GHP w/polyester (Mylar) insert Garlock® 3000, 3100, 3200, 3300 PCTFE (replaces Kel-F®) Gylon® 3500, 3504, 3510 PTFE (25% glass filled, virgin) Grafoil® Gr. GHR w/316 STS insert Buna-N NBR Neoprene® Viton® consult factory for others
8	Cushion	Garlock® IFG-5500					Grafoil® Gr. GHP w/polyester (Mylar) insert Garlock® 3000, 3100, 3200, 3300 PCTFE (replaces Kel-F®) Gylon® 3500, 3504, 3510 PTFE (25% glass filled, virgin) Grafoil® Gr. GHR w/316 STS insert Buna-N NBR Neoprene® Viton® consult factory for others
9	Shield <sup>1</sup>	None					ASTM D351 Mica Gr. V-4 PCTFE (replaces Kel-F®)
48	Glass	Reflex or transparent style tempered Borosilicate					Aluminosilicate (Transparent only)
100	Cap screw or U-bolt	AISI 4140 or 4142 Alloy steel per ASTM A193 Gr. B7	ASTM A193 316 STS Gr. B8M Cl. 2		AISI 4140 or 4142 Alloy steel per ASTM A193 Gr. B7	ASTM A320 Alloy steel Gr. L7	ASTM A153 galvanized steel ASTM A193 Gr. B7M ASTM A320 Gr. L7M
125	Washer	ASTM B633 Zinc plated carbon steel	18-8 STS (302-304 STS)		ASTM B633 Zinc plated carbon steel	18-8 STS (302-304 STS)	None
331	Band	Rubber					None

**NOTE**

- Under no circumstances should shields be used in reflex style gauges, as they will keep the fluid from coming into contact with the reflective prisms, thereby prohibiting visibility of the liquid level in the gauge.

**PENBERTHY MODELS RM AND TM DIRECT READING LIQUID LEVEL GAUGES**  
**MATERIAL SPECIFICATIONS – MODELS RMR/TMR**

**MODELS RMR AND TMR MATERIALS**

Ref. no.	Description	Standard materials					Optional materials
		Carbon steel to -20°F	STS Wetted to -20°F	STS Construction to -325°F	Sour gas service to -20°F	Low-temp steel to -50°F	
1	Cover	size 1 - 3	ASTM A516 Carbon steel Gr. 70	ASTM A240 316/316L STS	ASTM A516 Carbon steel Gr. 70	ASTM A516 Carbon steel Gr. 70/S5 -50°F	ASTM A351 304/304L STS Gr. CF3 ASTM A182 Gr. F51 Duplex 2205 STS ASTM A494 Hastelloy B® Gr. N-12MV ASTM A352 Carbon steel Gr. LCB ASTM A743 Alloy 20 Gr. CN7M ASTM B564 Monel® 400 N04400 ASTM A494 Hastelloy C® Gr. CW12MW ASTM A123 galvanized steel
		size 4 - 9	ASTM A105 (forged) Carbon steel	ASTM A351 316/316L STS (cast) Gr. CF3M	ASTM A105 (forged) Carbon steel	ASTM A350 (forged) Carbon steel Gr. LF2 Cl. 1	
2	Chamber	ASTM A105 (forged) Carbon steel	ASTM A276 316/316L STS		ASTM A105 (forged) Carbon steel per NACE MR0175 and/or MR0103	ASTM A516 Carbon steel Gr. 70/S5 -50°F	ASTM A276 304/304L STS ASTM A276 Duplex 2205 STS ASTM B164 Monel® 400 ASTM B473 Alloy 20 (CARP 20 Cb3)® ASTM B335 Hastelloy B® ASTM B575 Hastelloy C® 276 ASTM A123 galvanized steel
4	Nut	ASTM A194 Carbon steel Gr. 2 or 2H		ASTM A194 316 STS Gr. 8M	ASTM A194 Carbon steel Gr. 2 or 2H	ASTM A194 316 STS Gr. 8M	ASTM A153 galvanized steel ASTM A194 Gr. 2HM
7	Gasket	Garlock® IFG-5500					Grafoil® Gr. GHP w/polyester (Mylar) insert Garlock® 3000, 3100, 3200, 3300 PCTFE (replaces Kel-F®) Gylon® 3500, 3504, 3510 PTFE [25% glass filled, virgin] Grafoil® Gr. GHR w/316 STS insert Buna-N NBR Neoprene® Viton® consult factory for others
8	Cushion	Garlock® IFG-5500					Grafoil® Gr. GHP w/polyester (Mylar) insert Garlock® 3000, 3100, 3200, 3300 PCTFE (replaces Kel-F®) Gylon® 3500, 3504, 3510 PTFE [25% glass filled, virgin] Grafoil® Gr. GHR w/316 STS insert Buna-N NBR Neoprene® Viton® consult factory for others
9	Shield <sup>(1)</sup>	None					ASTM D351 Mica Gr. V-4 PCTFE (replaces Kel-F®)
48	Glass	Reflex or transparent style tempered Borosilicate					Aluminosilicate (Transparent only)
100	Cap screw or U-bolt	AISI 4140 or 4142 Alloy steel per ASTM A193 Gr. B7	ASTM A193 316 STS Gr. B8M Cl. 2	AISI 4140 or 4142 Alloy steel per ASTM A193 Gr. B7	ASTM A320 Alloy steel Gr. L7	ASTM A153 galvanized steel ASTM A193 Gr. B7M ASTM A320 Gr. L7M	
125	Washer	ASTM B633 Zinc plated carbon steel	18-8 STS (302-304 STS)	ASTM B633 Zinc plated carbon steel	18-8 STS (302-304 STS)	None	
331	Band	Rubber					None

**NOTE**

- Under no circumstances should shields be used in reflex style gauges, as they will keep the fluid from coming into contact with the reflective prisms, thereby prohibiting visibility of the liquid level in the gauge.

**Gaugecocks**

Penberthy Series 100 through 700 offset and straight pattern gaugecocks isolate the gauge chamber from the liquid contents of the vessel. Gaugecocks can be factory assembled in a variety of configurations.

SIDE CONNECTED GAUGE W/GAUGECOCKS

END CONNECTED GAUGE W/GAUGECOCKS

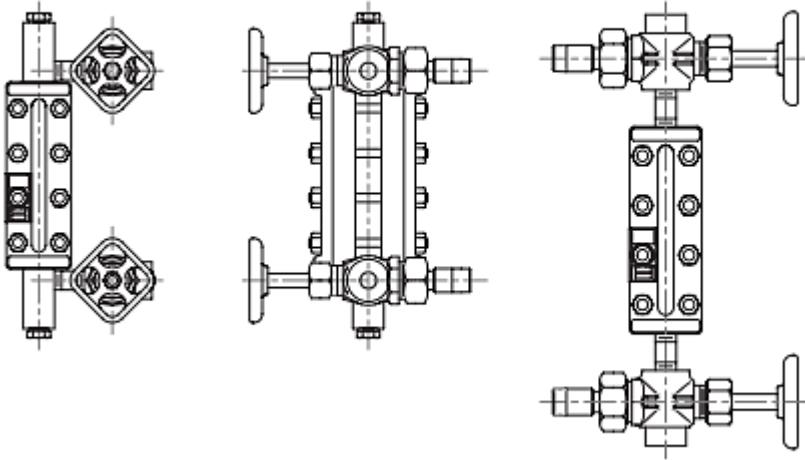

**Flexible fiberglass insulation blanket**

Lightweight, silicone coated fiberglass cover and liner, with or without PTFE window. Can be used with frost proof extensions and illuminators.

**External heating/cooling chamber**

Double sided or single sided, does not contact liquid inside chamber.

**Internal heating/cooling chamber**

Heating/cooling tube passes through the inside of the gauge and is in direct contact with liquid

**Frost-proof extensions**

Clear plastic windows that fit over the visible part of the glass in flat glass gauges. In low temperature applications, they inhibit build-up of frost over the visible part of the gauge, preventing obstruction of the liquid level view

**Gauge scales**

Attach to gauge cover to provide a graduated read out of liquid level. Available in a variety of units, feet/inch and meter/centimeter are standard

**Illuminators**

Complementary illuminators are designed to improve liquid level observation by providing proper light distribution over the entire visible length of the transparent gauge when ambient light is insufficient. The illuminator is designed to be mounted readily on virtually any gauge.

Continuous LED illuminators are available in sections up to 74" long. Multiple illumination sections can be stacked to accommodate virtually any visible length

LED ILLUMINATOR

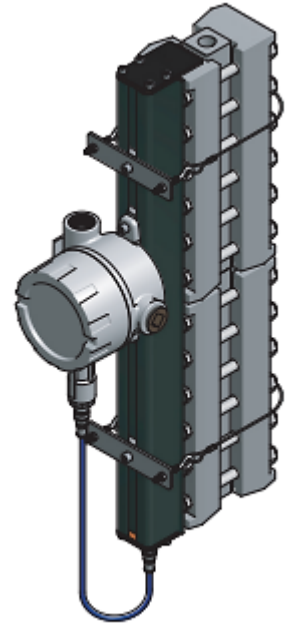

**PENBERTHY MODELS RM AND TM DIRECT READING LIQUID LEVEL GAUGES**  
**ORDERING INFORMATION - PART 1**

**SELECTION GUIDE**

**Example:** 04 RM 7 C C C X

No. of sections	01	02	03	04	05	06	07	08	09	10
1 Section										
2 Section										
3 Section										
4 Section										
5 Section										
6 Section										
7 Section										
8 Section										
9 Section										
10 Section										

**Gauge type**

<b>RM</b>	MP Reflex gauge
<b>TM</b>	MP Transparent gauge
<b>RMR</b>	MP Reflex gauge with recessed gasket chamber
<b>TMR</b>	MP Transparent gauge with recessed gasket chamber

**Glass size**

<b>1</b>	Size 1
<b>2</b>	Size 2
<b>3</b>	Size 3
<b>4</b>	Size 4
<b>5</b>	Size 5
<b>6</b>	Size 6
<b>7</b>	Size 7
<b>8</b>	Size 8
<b>9</b>	Size 9

**Wetted parts material (chamber)**

<b>C</b>	Carbon steel (standard)
<b>S</b>	316/316L Stainless steel
<b>M</b>	Monel
<b>A</b>	Alloy 20
<b>H</b>	Hastelloy C
<b>F</b>	304/304L Stainless steel
<b>D</b>	Duplex 2205
<b>L</b>	Low temp. CS to -50°F
<b>N</b>	Normalized A105

**Cover material**

<b>C</b>	Carbon steel (standard)
<b>S</b>	316/316L stainless steel
<b>F</b>	304/304L stainless steel
<b>D</b>	Duplex 2205
<b>L</b>	Low temp. CS to -50° F
<b>N</b>	Normalized A105
<b>E</b>	Galvanized carbon steel

**Bolting material**

<b>C</b>	STL A193 B7/A194 2H (standard)
<b>S</b>	SST A193 B8M/A194 8M
<b>L</b>	LT A320 L7/A194 8M
<b>N</b>	STL NACE A193 B7M/A194 2HM
<b>A</b>	LT NACE A320 L7M/A194 7M
<b>E</b>	SST NACE A193 B8MA/A194 8MA

**NACE MR-01-75 and/or MR-01-03**

<b>X</b>	None
<b>W</b>	NACE wetted
<b>E</b>	Environmental

**PART 2 - PAGE 12**

C B X

**PART 3 - PAGE 13**

X X X X X X X X X

**PART 4 - PAGE 14**

G G S B X X X X



**PENBERTHY MODELS RM AND TM DIRECT READING LIQUID LEVEL GAUGES**  
**ORDERING INFORMATION - PART 2**

**PART 1 - PAGE 11**

04 RM 7 C C C X

**SELECTION GUIDE - PART 2**

**Example:**

**End connection size**

**C** 1/2" (Standard)

**E** 3/4"

**F** 1" (flange only)

**H** 1 1/2" (flange only)

**J** 2" (flange only)

**End connection type**

**B** NPT female (standard)

**D** Socketweld female

**N** Raised face SO

**P** Flat face SO

**R** RTJ SO

**S** Raised face SW

**T** Flat face SW

**U** RTJ SW

**V** Raised face WN

**W** Flat face WN

**Y** RTJ WN

**F** Vent and drain plugged

**G** Drain plugged

**H** Vent plugged

**J** Socketweld male

**End connection pressure class**

**X** None

**1** 150#

**3** 300#

**6** 600#

**9** 900#

**F** 1500#

**T** 2500#

**C B X**

**PART 3 - PAGE 13**

X X X X X X X X X X



**PART 4 - PAGE 14**

G G S B X X X X

**PENBERTHY MODELS RM AND TM DIRECT READING LIQUID LEVEL GAUGES**  
**ORDERING INFORMATION - PART 3**

**PART 1 - PAGE 11**

**SELECTION GUIDE - PART 3**

**PART 4 - PAGE 14**

04 RM 7 C C C X

**Example:** X X X X XXXXX G G S B X X X X

**PART 2 - PAGE 12**

C B X

**Side connection size**

- X None
- C 1/2" (standard)
- E 3/4"
- F 1" (flange only)
- H 1 1/2" (flange only)
- J 2" (flange only)

**Side connection type**

- X None
- B NPT female (standard)
- D Socketweld female
- M NPT male
- N Raised face SO
- P Flat face SO
- R RTJ SO
- S Raised face SW
- T Flat face SW
- U RTJ SW
- V Raised face WN
- W Flat face WN
- Y RTJ WN
- L Lap joint

**Side connection pressure class**

- X None
- 1 150#
- 3 300#
- 6 600#
- 9 900#
- F 1500#
- T 2500#

**Side connection location**

- X None
- S Right side connected (standard)
- L Left side connected
- B Back connected
- F Front connected
- G One bottom right
- H One bottom left
- J One top right
- K One top left
- M One bottom back

**Connection dimension**

- XXXXX None
- 00000 Inches (first 3 digits = number of whole inches, last 2 digits = fraction of an inch in hundredths)

**PENBERTHY MODELS RM AND TM DIRECT READING LIQUID LEVEL GAUGES**  
**ORDERING INFORMATION - PART 4**

**PART 1 - PAGE 11**

04 RM 7 C C C X

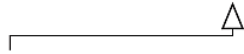

**PART 2 - PAGE 12**

C B X

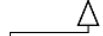

**PART 3 - PAGE 13**

X X X X X X X X X

**SELECTION GUIDE - PART 4**

Example:		G	G	S	B	X	X	X	X
<b>Gasket material</b>									
G	Grafoil/Mylar								
S	Grafoil/SS insert								
T	ePTFE (Gore Gr)								
K	Garlock 3300								
L	Gylon 3510								
Y	Gylon 3504								
A	Garlock® IFG-5500 (Standard)								
U	Buna-N NBR								
V	Viton®								
D	25% glass filled PTFE								
P	PCTFE (KEL-F)								
C	TopChem 2000								
<b>Cushion material</b>									
G	Grafoil/Mylar								
S	Grafoil/SS insert								
T	ePTFE (Gore Gr)								
K	Garlock 3300								
L	Gylon 3510								
Y	Gylon 3504								
A	Garlock® IFG-5500 (Standard)								
U	Buna-N NBR								
V	Viton®								
D	25% glass filled PTFE								
P	PCTFE (KEL-F)								
C	TopChem 2000								
<b>Paint specification</b>									
X	None								
S	Standard								
O	Offshore Paint								
<b>Option 1</b>									
X	None								
A	1 External htg/clg chbr.								
B	1 Welded support bracket								
C	2 Welded support brackets								
D	3 Welded support brackets								
K	Belleville washers								
N	Per UOP spec 6-20								
<b>Option 2</b>									
X	None								
R	Belleville washers (used when support bracket is selected in Option 1)								
<b>Option 3</b>									
X	None								
B	Mica Shields V2/V4 (.005-.007" thick)								
C	PCTFE shields (KEL-F)								
D	Mica Shields V2/V4 (.009-.012" thick)								
<b>Option 4</b>									
X	None								
N	Aluminosilicate glass								
U	For steam service								
<b>Option 5</b>									
X	None								
G	Schedule 160 Piping								



16633 Foltz Parkway, Strongsville, OH 44149 USA • Telephone: +440-572-1500  
[www.PenberthyProcess.com](http://www.PenberthyProcess.com) • [sales@PenberthyProcess.com](mailto:sales@PenberthyProcess.com)